

Service  
Service  
Service



# Service Manual

## CONTENTS

- Dimensions
- Technical data
- Remarks/Warning
- Circuit diagrams:
- Adjustments
  - A Supply
  - B Video Servo 1
  - B' Audio demodulators
  - C Video Servo 2
  - D Control 1
  - D' Control 1 (Datic)
  - E Deck
  - P Control 2
- Printed boards:
  - A Supply
  - B Video Servo 1
  - C Video Servo 2
  - D Control 1
  - E Deck
  - P Control 2
- Wiring diagram
- Exploded view player
- List of mechanical and electrical parts player
- Exploded view deck
- List of mechanical and electrical parts deck

Safety regulations require that the set be restored to its original condition and that parts which are identical with those specified be used.



DIMENSIONS

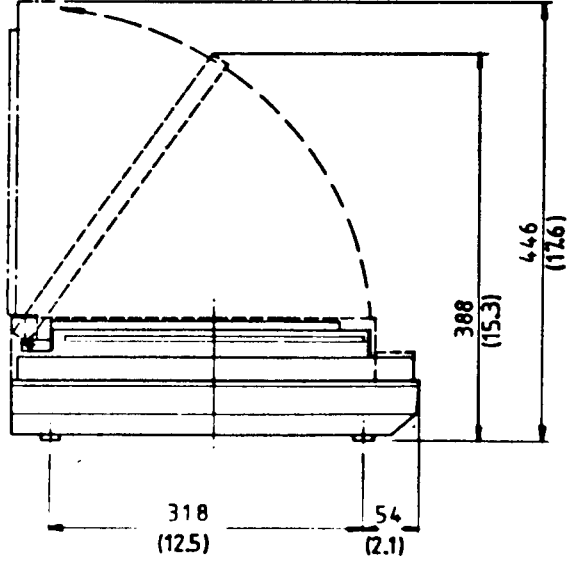
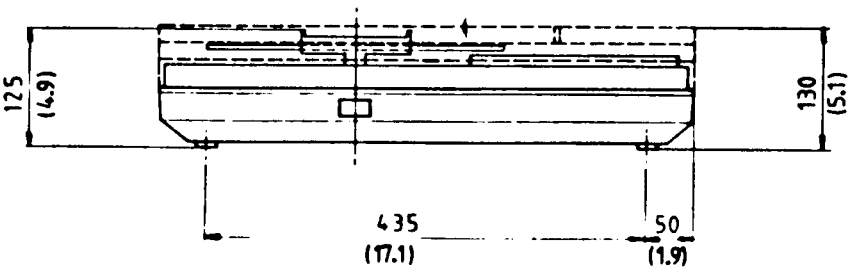
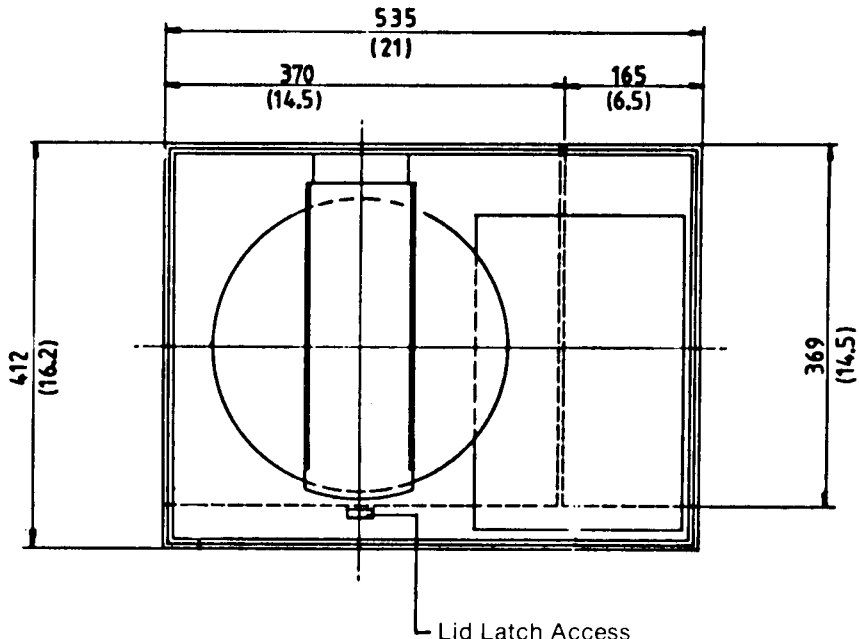

dims. are in mm  
(inches)

## TECHNICAL DATA PLAYER

Mains voltage : 120/220 V  $\pm$  10%  
Mains frequency : 50/60 Hz  
Power consumption : 50 W max.  
Fuses : 2.5 A slow

### Appearance and connections:

Dimensions : 535x412x125 mm  
Weight :  
Colour : not applicable  
Brand indication : not applicable  
Audio out (L & R) : Dual R.C.A. phono jack  
Video-out : BNC  
Pre-amp.-out : BNC  
(HF audio + video)  
Computer interface : Subminiature "D" 25 pins

### Video output signal : NTSC

Output level :  $V_O = 1.0 \pm 0.1 V_{pp}$ , into 75  $\Omega$   
positive video signal  
Band width : 4.2 MHz ( $-3$  dB)  
Signal to noise ratio :  $> 37$  dB, unweighted; disc  
dependent\*  
Colour subcarrier frequency : 3579545 + 50 Hz  
Time base instability :  $< 20$  nsec., except during goto and  
trick mode

### Audio output signal

Output level :  $V_O = 0.65 V_{rms} \pm 1.5$  dB at  
1 kHz - 100% modulation  
Bandwidth : 40 Hz-20 kHz ( $-3$  dB)  
Signal to noise ratio :  $> 55$  dB\*  
Number of channels : 2  
Channel unbalance :  $< 1$  dB  
Channel crosstalk :  $\leq -55$  dB, measured at  
1 kHz-100% modulation  
Distortion :  $< 1\%$ , measured at 1 kHz-100%  
modulation

### Pre-amp. out

Output level :  $70 \pm 20$  mV<sub>pp</sub> into 50  $\Omega$   
Bandwidth : 5 kHz-15 MHz ( $-3$  dB)

**Computer interface** : Format, 8 bits parallel with  
handshake TTL compatible

\*Carrier to noise ratio of the main carrier of the  
disc  $\geq 60$  dB

## TECHNICAL DATA DECK

Weight : approx 3 kg  
Supply voltages : + 12 V  $\pm 5\%$   
- 12 V  $\pm 5\%$   
Current consumption :  $< 180$  mA  
Laser voltage : ignition  $\geq 8.000$  V d.c.  
operation  $1150 \pm 100$  V d.c.  
Laser current : operation  $5 \pm 0.2$  mA  
Laser type : He-Ne Laser  
1.5  $\pm 0.5$  mW  
632.8 nm  
Objective : 20 x 0.40 N.A.  
Disc clamping : automatically with lid  
closure  
Spindle type : conical 35 mm  
auto centring of 8"-12"  
optical video discs  
Inner read out diameter :  $\geq 108$  mm  
Outer read out diameter :  $\leq 293$  mm  
Turntable motor : d.c. motor  
- direction of rotation : counter clockwise seen  
from the objective  
- rotation speed : 0 ... 2.000 r.p.m.  
- start up time :  $\leq 8.5$  sec (12" disc)  
Slide drive motor : d.c. motor  
- direction of movement : reversable  
- search time :  $5 \pm 1$  sec (12" disc)  
Operating position : horizontal  $\pm 20^\circ$   
Allowed ambient temp. :  $15^\circ\text{C} < t < 60^\circ\text{C}$  acc. spec.  
 $5^\circ\text{C} < t < 15^\circ\text{C}$  } working  
 $60^\circ\text{C} < t < 65^\circ\text{C}$  }

## REMARKS

### 1. Exchange of the panels

The Video Servo 1 panel and Video Servo 2 panel, have to be adjusted after replacement. The necessary adjustments are B7, B8 and C1 (focus drive, tangential servo and MTF circuit).

The supply panel, control 1 panel, control 2 panel and the deck can be exchanged without any adjustment.

### 2. Circuit diagrams

- a. The voltages indicated in the diagrams have been measured in the "play" mode of the set. The voltages under deviating circumstances are indicated between brackets ( ).
- b. The oscillograms have been measured in the "still" mode, with the colour bar pattern of the test disc as video signal.

### 3. Printed Circuit Boards

The drawings of the PCBs are accompanied by a component search system, by means of which it is possible to quickly determine the location of the components.

A quadrantal division has been drawn around the PCB and a Table with all the occurring components is given next to the PCB.

*For example:*

2018 B5 means that capacitor 2018 is located in quadrant B-5.

### 4. Optical adjustments

The light path in the player consists of very critically adjusted components.

If a deviation has been observed, one should first convince oneself of the fact that the deviation is located in the optical part and not in the electronic circuits in the rest of the set, before making a beginning with the optical adjustments in the deck.

If necessary, replace the complete deck to locate the deviation.

## WARNINGS

1. While repairing and measuring in the electric circuits, one should keep in mind that part of the circuit on the supply panel remains under voltage when the set has been switched off (lid open).  
Therefore be sure to always remove the mains plug from the socket outlet before replacing any components.
2. The laser used in this set is a HeNe laser which emits visible light with power of 1 mW and which is classified in the category "class 3B" laser.  
If, during repair in the deck, the objective unit is removed, a parallel laser beam emerges from the objective hole.

**Avoid looking directly into the laser beam as this might cause permanent injury to the eye.**

## ADJUSTMENTS

### Optical adjustments

For the optical adjustments the following items are required:

1. Optical adjustments set: 4822 395 30124 (220 V)  
or: 4822 395 30233 (110 V)

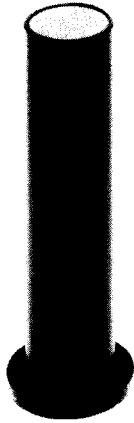

— mirror alignment turret;

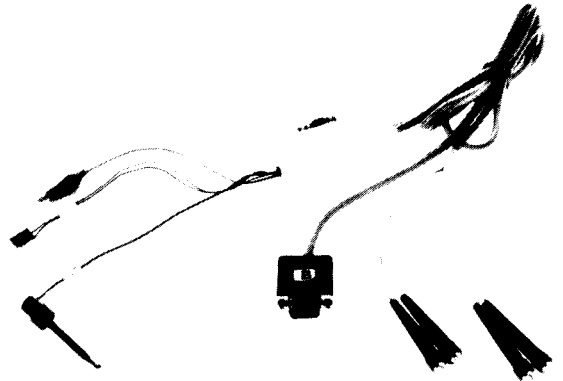

— test lead;



— pupil-filling meter;

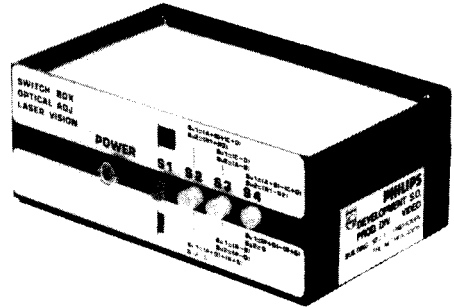

— switch box;

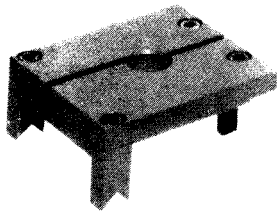

— test jig;

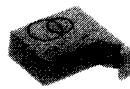

— target block;



— key for adjustment of  $\frac{1}{4}\lambda$  plate;

2. Double-beam oscilloscope.
3. Signal generator, 10 Hz - 100 kHz.
4. Variable d.c. power supply.
5. Set of Torx screwdrivers (4822 395 50145).
6. Test disc 8" (approx. 20 cm dia.) 4822 397 30097.
7. Plug adaptor 4p (C7X-Stocko) 4822 267 40514.

**Operations to be carried out prior to optical-path adjustments.**

1. Remove the covers (items 143, 153 and 511) and the slide drive mechanism (item 129) as shown in Fig. 1. Remove the deck from the cabinet by undoing the four fixing screws. Place the deck with its rear side on the rear cabinet edge and place cover 143 underneath the front, as indicated in Fig. 2.

**2. Switching on the laser (servo section of the player inoperative)**

- Unplug connectors B16 and B17 on the connector panel of the deck.
- Unplug connectors B26 and B27 on the slide panel of the deck.
- Short-circuit C and E of TS6148 on the power supply panel by means of an insulated test clip.
- Switch on the laser by switching on the player.

POSITION OF CONNECTORS

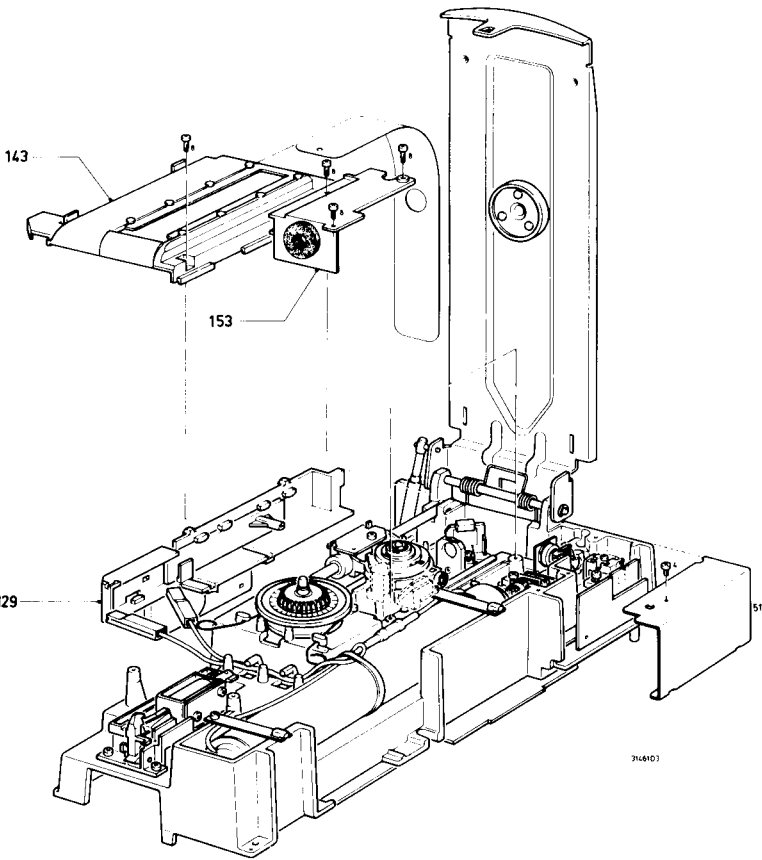
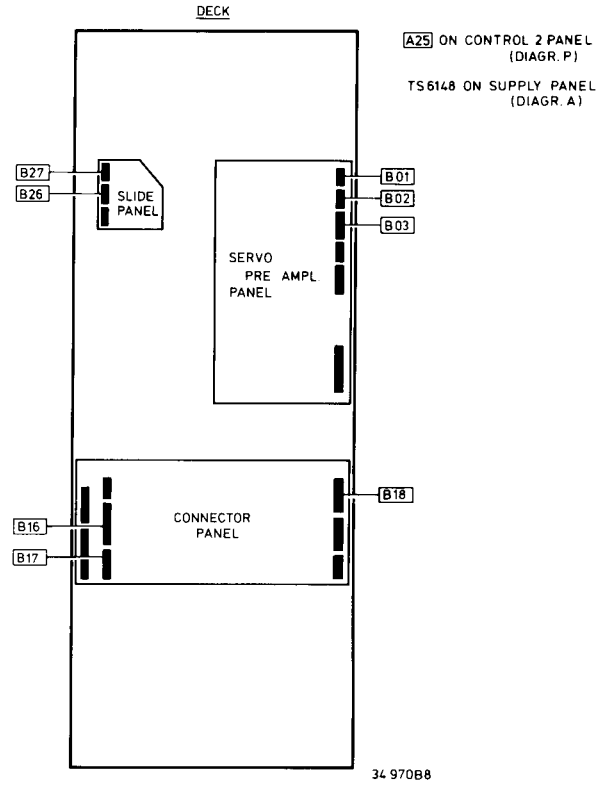

Fig. 1

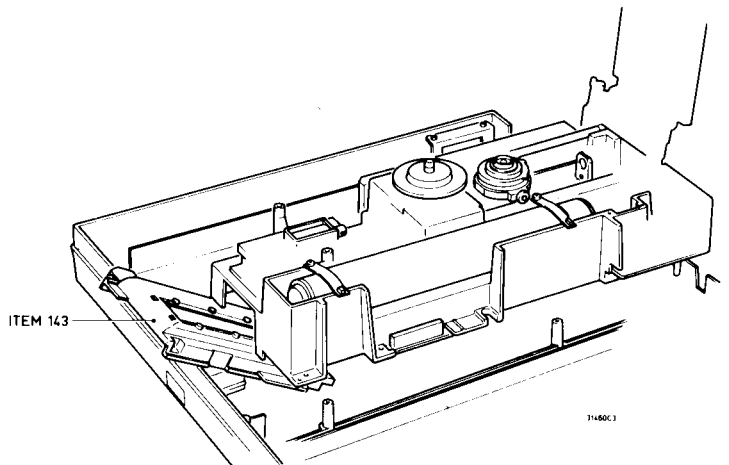

Fig. 2

### 3. Adjusting the manipulators

The manipulators for the spot lens, the radial and tangential mirrors and the photo-diode are constructed as shown in Fig. 3a. The pivots A and B are integrated in the manipulator material, so that their adjustment range is limited. If the adjustment is such that an upward movement is obtained (turn set-screw clockwise) this will present no problems.

However, if subsequently a downward adjustment is required (turn set-screw anti-clockwise) the pivot will no longer exert an adequate spring force on the manipulator after some turns. In that case it is necessary to re-energize the manipulator by turning the set-screw six turns further anti-clockwise and pressing the manipulator against its stop by means of the screwdriver. After this turn the set-screw clockwise until the manipulator has reached the desired position.

The same procedure must be adopted for the folding mirror, although a different construction is employed (see Fig. 3b).

The pivots A and B are energized by turning set-screw E four turns anti-clockwise and then urging the mirror holder upward against the set-screw.

Pivot C is actuated by turning set-screw D four turns anti-clockwise and pressing the manipulator towards set-screw D.

It is obvious that the range of the manipulator adjustments described above is not unlimited. If it is necessary to repeat the energization of the manipulators more than three times, the entire manipulator must be replaced.

### 4. Connecting the switch box

- Connect the oscilloscope to the rear of the switch box. Connect the A-channel to BU1 and the B-channel to BU2.
- Connect the pupil-filling meter to the receptacle marked A and the test lead to receptacle B.

### 5. Removing and mounting the objective unit (see Fig. 4)

Indicate the position of the obj. unit before removing. The objective holder has been snapped onto the objective magnet and must be removed with care, by tilting the flap as indicated in Fig. 4.

When remounting the objective, one of the three clamping lugs of the objective holder must snap onto the magnet with an audible click.

Check whether the position of the objective is in line with the earlier indicated position.

#### Caution:

**Never look directly into the laser beam when the objective has been removed. The parallel beam may cause permanent eye damage.**

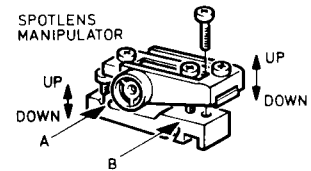

31451A3

Fig. 3a

FOLDING MIRROR MANIPULATOR

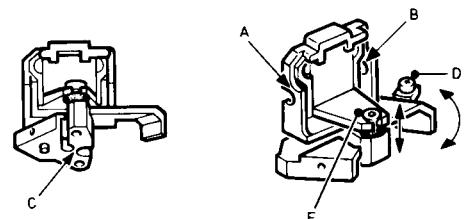

31453A3

Fig. 3b

### CHECK MATRIX OPTICAL ADJUSTMENTS

Check and/or adjust \ Replaced part	Grating	Spotlens	$\frac{1}{4}\lambda$ plate	Fold. mir.	Rad. mir. + tang. mir.	Photo diode	objective
Laser	x	x	x	x	x	x	
Grating/spotlens	x	x				x	
$\frac{1}{4}\lambda$ plate			x				
Folding mir.		x		x	x		
Radial mir.					x		
Tangential mir.					x		
Objective							x
Cyl. lens/ph. diode						x	

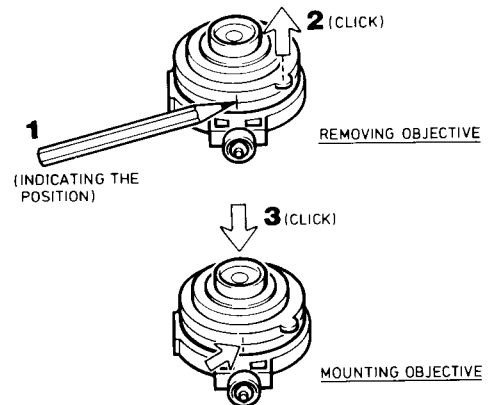

34977A3

Fig. 4

## Adjusting the light path (see Fig. 5)

### 1. Coarse adjustment of the light path

- a. Place the target block into pos. 1 on the deck.
- b. Adjust the spot lens with screws A and B (in turn) until the laser beam fills target 1 completely.
- c. Place the target block into pos. 2.
- d. Adjust the folding mirror with screws D and E (in turn) until the laser beam fills target 2 completely.
- e. Remove the objective from the objective slide.
- f. Place the test jig onto the slide guide-points above the objective slide.
- g. Place the mirror alignment turret into the hole in the jig and adjust the radial and tangential mirrors in the slide by means of screws F and G until the shadow of the crossing of the lines lies within the circle on the frosted glass screen.
- h. Proceed with the fine adjustment of the light path as described in 2.

### 2. Fine adjustment of the light path

- a. Remove the objective from the slide and place the test jig on the slide guide-points above the objective slide.
- b. Place the pupil-filling meter into the objective holder through the hole in the test jig. The pins on the meter should engage the grooves in the jig.
- c. Set both channels of the oscilloscope to 0.5 V/cm (DC) and 0.5-ms time base. Adjust the lines on the oscilloscope to the zero line by means of the shift controls.
- d. Switch on the switch box with the "POWER" button and press S1 and S3.
- e. Switch on the laser.
- f. Move the test jig to the extreme position in the direction of the folding mirror and adjust the spot lens with screws A and B (in turn) until the horizontal lines on the oscilloscope coincide with the zero line in the best possible manner.
- g. Move the test jig to the extreme position in the direction of the turntable motor and adjust the folding mirror with screws D and E (in turn) until the lines coincide with the zero line of the oscilloscope in an optimum manner.
- h. Repeat adjustments f and g a few times until the deviation of the two lines relative to the zero line is not more than 50 mV when the test jig is moved to and fro.
- i. Remove the pupil-filling meter from the test jig and place the mirror-alignment turret on the test jig.
- j. Adjust the radial and tangential mirror in the slide by means of screws F and G so that the shadow of the crossing of the lines lies within the circle on the frosted glass screen.
- k. Optimize the adjustment of the spot lens with screws A and B, as described in f.
- m. Remount the objective.

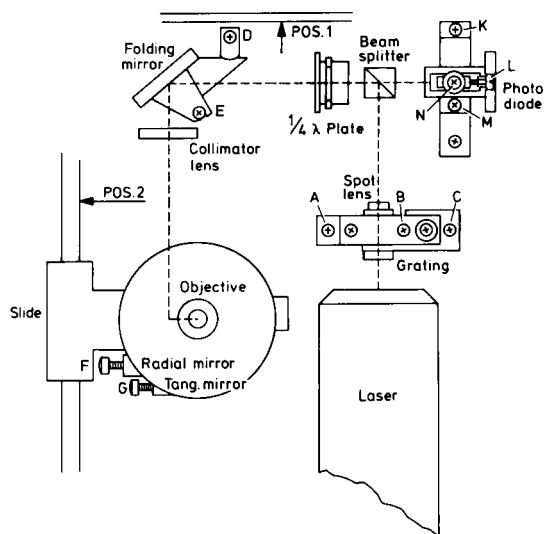

Fig. 5

31457B3



### 3. Adjusting the photo-diode (X-Y direction)

- Insert connectors B01, B02 and B03 of the servo-preamp into the receptacles of the test lead. Insert connector B18 of the test lead into receptacle B18 on the connector panel, using the plug adaptor 4p. Connect the earth clip to the mass of the deck.
- Connect the signal generator, the oscilloscope and the d.c. power supply, as shown in Fig. 6.
- Place the 8" test disc with its unrecorded side on the turntable and bring the objective slide to a position about halfway the disc.
- Switch on the laser.
- Switch off S1 and switch on S4 of the switch box.
- Set the oscilloscope to 0.5 V/div. and a time base of 2 ms.
- Set the frequency of the signal generator to approx. 30 Hz and adjust the amplitude of the generator signal and the power supply so that the objective starts to oscillate freely and an S-curve is displayed on the oscilloscope screen (beam A). The  $(R_1 - R_2)$  signal on beam B should be minimum ( $\leq 100$  mVpp). The amplitudes and waveform are shown in Fig. 7.
- Adjust screws K and M in turn so that the amplitude of the S-curve is a maximum. If the minimum value of the voltage (1 V) is not reached the components in the light path must be inspected for dust and other contaminants. If necessary, clean these components.
- Switch on S3 and adjust screws K and M in turn until the amplitude of the difference signals (A-B) and (C-D) is  $\leq 100$  mV.
- If no S-curve is found S2 must be switched on to display the sum signal  $(A+B) + (C+D)$  from the photodiodes. Adjust screws K and M for a maximum sum signal and repeat adjustments g to i inclusive.

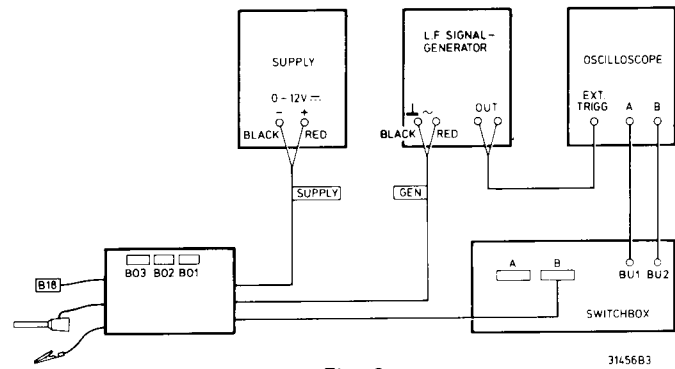

Fig. 6

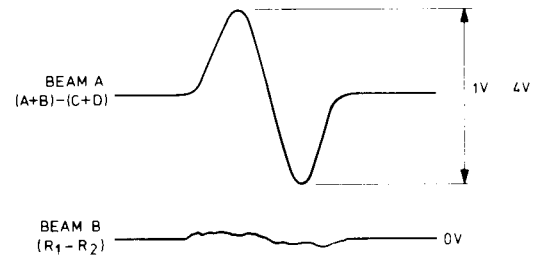

Fig. 7

### 4. Adjusting the $\frac{1}{4}\lambda$ plate

- Connect the player as described under 3a and 3b (adjustment of the photo-diode by means of the S-curve).
- Switch off S1 and switch on S2 of the switch box.
- The sum signal  $(A+B) + (C+D)$  is displayed on the A-channel of the oscilloscope (see Fig. 8).
- Adjust the  $\frac{1}{4}\lambda$  plate, using the accessory key, so as to obtain a minimal ripple on the peak of the sum signal.

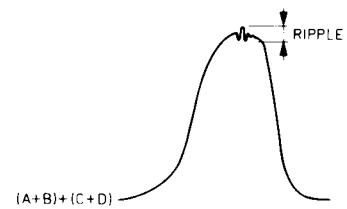

Fig. 8

Remove the connectors from the receptacles of the test lead, refit all the connectors in the player, remove the short circuit of TS6148 and mount the slide drive mechanism, so that the player is restored to the normal operating condition.

### 5. Adjusting the grating

- Put on the 8" test disc and switch on the player. Select picture number 17000 (still picture).
- Unplug connector A25 (slide motor) on the Control 2 panel.
- Unplug connector B26 (rad. mirror) on the slide panel.
- Unplug connector B02 on the servo-preamplifier panel and insert this connector into receptacle B02 of the test lead. Connect the test lead to the switch box.
- Switch off S1 on the switch box and switch on S4, so that the radial difference signal  $(R1-R2)$  appears on the B-channel of the oscilloscope.
- Turn screw C clockwise until the grating lens has approximately reached the extreme position and the oscilloscope displays the radial difference signal for the 2.5 and 1.66  $\mu\text{m}$  track pitch (see Fig. 10). If necessary, search for this signal by manually varying the position of the objective slide by rotating the gear wheel.

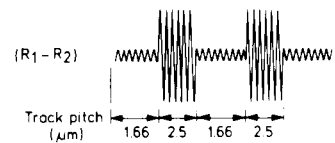

Fig. 9

- g. Turn screw C about 3 turns anti-clockwise until the radial difference signal is minimal for both track pitches. The position of the three spots is now exactly in line with the tracks.
- h. Move the objective slide until approx. picture number 16000 is displayed (track pitch  $1.4 \mu\text{m}$ ).
- i. Switch on S2 on the switch box. The radial sum signal (R1 + R2) is now displayed on the oscilloscope.
- j. Turn screw C anti-clockwise (about 1 turn) until the signal on the oscilloscope is minimal.
- k. Refit connectors B02, A25 and B26 and check the player for correct tracking.

## 6. Adjusting the photo-diode (Z-direction)

- a. Put the 8" test disc on the turntable and switch on the player. Search for a black picture (e.g. 5000).
- b. Apply a 1 KHz sinewave signal from the signal generator to point 6-IC6209-2A (focus drive) via 27 kv. The accessory test lead may be used for this purpose. Connect the correspondingly marked terminals to earth and to point 6-IC6209-2A focus-drive. Connect the cable marked "GEN" to the output of the signal generator.
- c. Measure the HF signal on C-TS6104 by means of the oscilloscope (approx. 600 mV.).
- d. Connect the 1 kHz signal to the other input of the oscilloscope and trigger on this signal.
- e. Adjust the amplitude of the signal from the signal generator so that a 1 kHz whistle is just audible from the objective and the oscilloscope displays a HF signal modulated with a 1 KHz sinewave (see Fig. 9).
- f. Loosen screw N slightly and adjust the position of the photodiodes with screw L until the amplitudes A of the HF signal have the same values as the amplitudes B.
- g. Fasten screw N again.

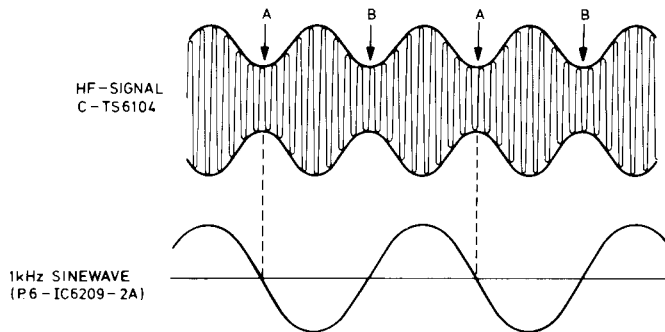

Fig. 10

31455A3

## 7. Objective

- a) Put the 8" test disc on the turntable and switch on the player.
- b) Search for picture number 450 (white).
- c) Turn the objective unit until the interference patterns at the left and the right side of the picture are minimum.

## ELECTRICAL ADJUSTMENTS PLAYER PART (see Fig. 11)

Equipment required for the electrical adjustments:

- Double-beam oscilloscope with delayed time base;
- HF generator (NTSC);
- LF generator;
- Voltmeter (preferably digital);
- Variable d.c. power supply;
- 8" test disc (approx. 20 cm dia.) 4822 397 30097.

### A. Power supply panel (circuit diagram A)

#### 1. Switched-mode power supply

- Measure the voltage on point C002 with the voltmeter.
- Adjust this voltage to +12 V ( $\pm 120$  mV) with R3011.

#### 2. Laser supply

- Measure the voltage on junction point R3066-R3067.
- Adjust this voltage to +5 V (= 5 mA laser current) with R3066.

#### 3. Tacho circuits

- Test disc on player; normal-play mode.
- Measure the voltage on the base of TS 6154.
- Adjust this voltage to +1.69 V with R3112.

### B. Video Servo 1 panel (circuit diagram B)

#### 1. Video demodulator 1

- Test disc on player, picture number 8600 (B/W bars), still picture.
- Measure the video signal on point C004 with the oscilloscope.
- Adjust for 1.5 Vp-p video signal with R3075.

#### 2. Video demodulator 2

- Test disc in player, picture no. 8600 (B/W bars), still picture.
- Short-circuit the base of TS 6113 to earth.
- Measure the video signal on point C004 with the oscilloscope.
- Adjust R3051 for a 1.5 Vp-p video signal.
- Remove the short-circuit.

#### 3. HF processor

- Mains switch on, cover open.
- Connect the HF generator to connectors B051 and B053 (earth) via a filter (Fig. 12).
- Set the generator to a frequency of 8 MHz and 20 mVp-p output voltage, unmodulated.
- Connect point C008 to earth.
- Measure the signal on point 5 of IC 6202 by means of the oscilloscope.
- Adjust L5001 for maximum signal amplitude.

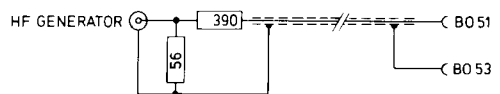

Fig. 12

#### 4. Audio drop-out detector

- Mains switch on, cover open.
- Connect the HF generator to the connectors B051 and B053 (earth) via a filter as shown in Fig. 12.
- Set the generator to a frequency of 400 kHz, unmodulated, and set the RF attenuation to 40 dB.
- Apply a voltage of 8 V d.c. (negative to earth) to point C008.
- Measure the signal on the base of TS 6118 by means of the oscilloscope.
- Adjust L5018 for maximum signal amplitude.

#### 6. 5% detector

- Test disc in the player, normal play mode.
- Measure the signal on the collector of TS6168 by means of the oscilloscope.
- Adjust L5034 for maximum signal amplitude.

#### 7. Focus drive

- Test disc in player, picture number 20000, still picture.
- Via a 100-kohm resistor apply a sinewave-signal having a frequency of 2.1 kHz and an amplitude of 1 V<sub>p-p</sub> to point 6 of IC6209-2A.
- Measure the signal on junction R3218-R3219 with channel A of the oscilloscope.
- Set the oscilloscope to X-deflection and apply the 2.1-kHz generator signal to X-input.
- Adjust R3223 so that the left-hand and right-hand side of the Lissajous figure are at the same level (see Fig. 14).

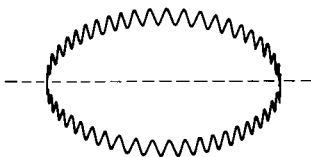

Fig. 14

#### 8. Tangential serve

- Test disc in player, picture number 16500 (blue), still picture.
- Turn potentiometer R3383 fully clockwise. Hazy horizontal bars will now appear in the picture.
- Turn potentiometer R3383 anti-clockwise until these bars just disappear.

#### C. Video Servo 2 panel (circuit diagram C)

##### 1. MTF circuit

- Connect the HF generator to connectors A011 and A012 (earth).
- Set the frequency to 3.58 MHz and the amplitude to 0.1 V<sub>p-p</sub>.
- Measure the signal on the emitter of TS6116 by means of the oscilloscope.
- Adjust L5005 for maximum signal amplitude.
- Remove the generator signal.
- Test disc in the player, picture number 180, still picture.
- Connect the oscilloscope to the VIDEO OUT connector (see circuit diagram B) and search for the multiburst signals in the VITS (line 20) by means of the delayed time base.
- Adjust R3057 so that the amplitude of MB IV = MBI (see Fig. 15).

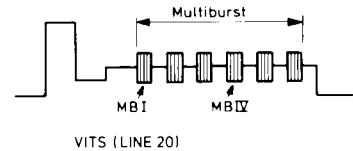

Fig. 15

## E. Deck electronics (circuit diagram E)

### 1. Radial gain (Gain)

- Test disc in the player, still picture.
- Measure the signal on connector B075 by means of the oscilloscope.
- Display the TPI pulse by means of the delayed time base.
- Adjust the pulse width to approx. 95  $\mu$ secs. with R3017 (Gain).

### 2. Radial offset (balance)

- Test disc in the player, still picture.
- Unplug connector A25 (slide motor) on the Control 2 panel.
- Unplug connector B26 (rad. mirror) on the slide panel.
- Connect connector B033 (substrate) to earth via a 180-kohm resistor.
- Measure the "rad. error" signal on connector B072 by means of the oscilloscope (d.c.).
- Adjust R3016 (Balance) so that the signal is symmetrical relative to the zero level (see Fig. 16).
- Remove the 180 kohm resistor and refit connectors A25 and B26.



Fig. 16

31458B3

### 3. Adjusting the slide end-stop (item 122 in exploded view drawing of deck)

- Test disc in the player, picture number > 1000, still picture.
- Press button "scan reverse" and keep it pressed. The objective slide now travels to the centre of the disc until the beginning of the disc is reached.
- Release the "scan reverse" button. The player now shows the lowest possible picture number which must be between 50 and 150. If not, adjust the set-screw of the opto-coupler panel, until the desired range has been reached, repeating above operations.
- Check whether the objective slide travels back from picture number 380 onwards, after pressing button "scan reverse".

# ELECTRICAL ADJUSTMENTS

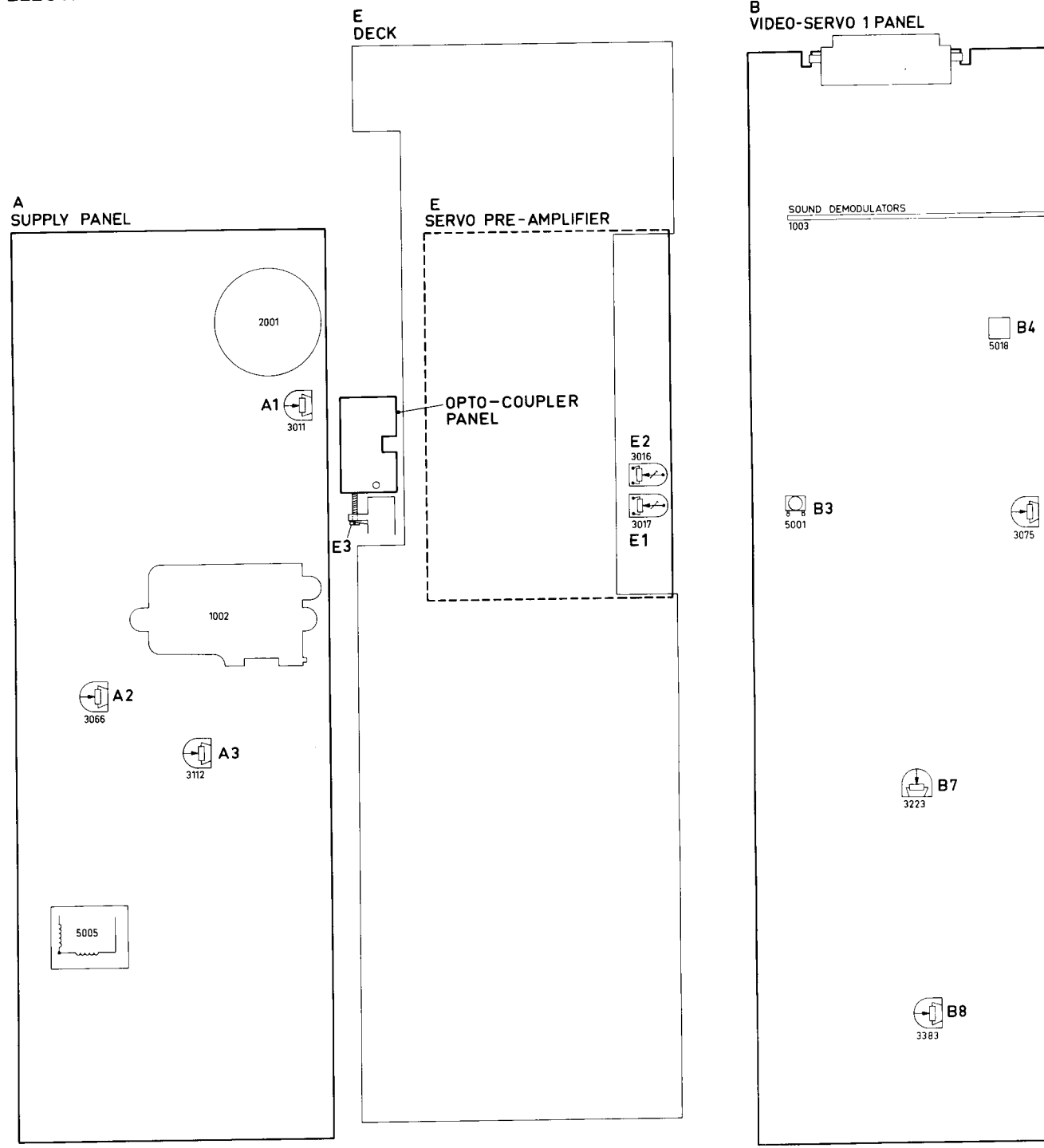

F

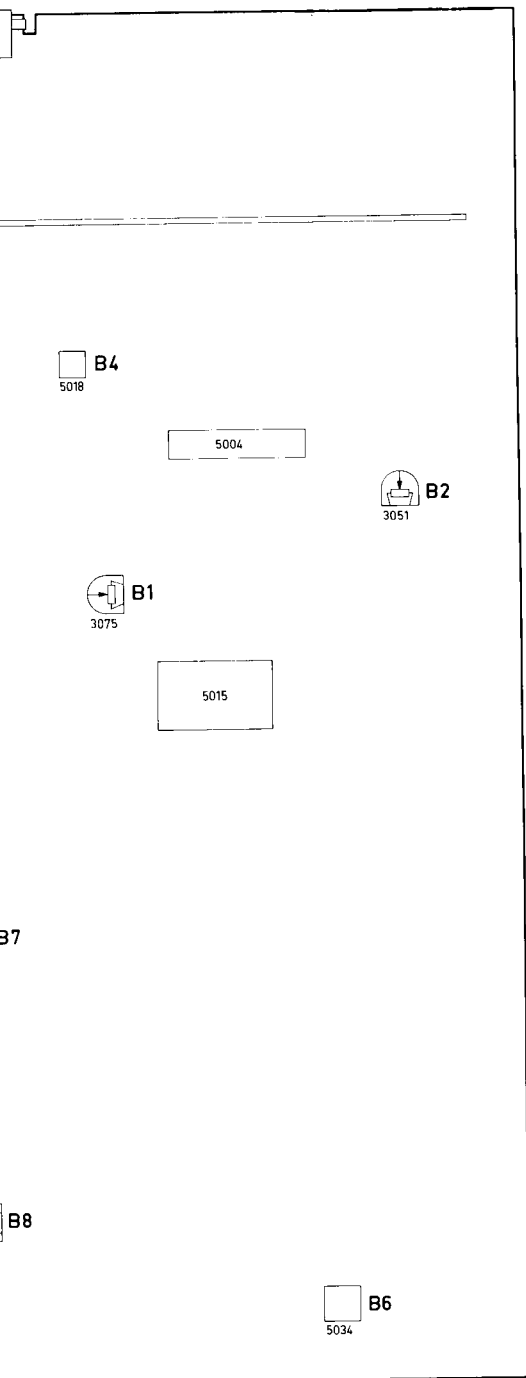

**C**  
VIDEO SERVO 2 PANEL

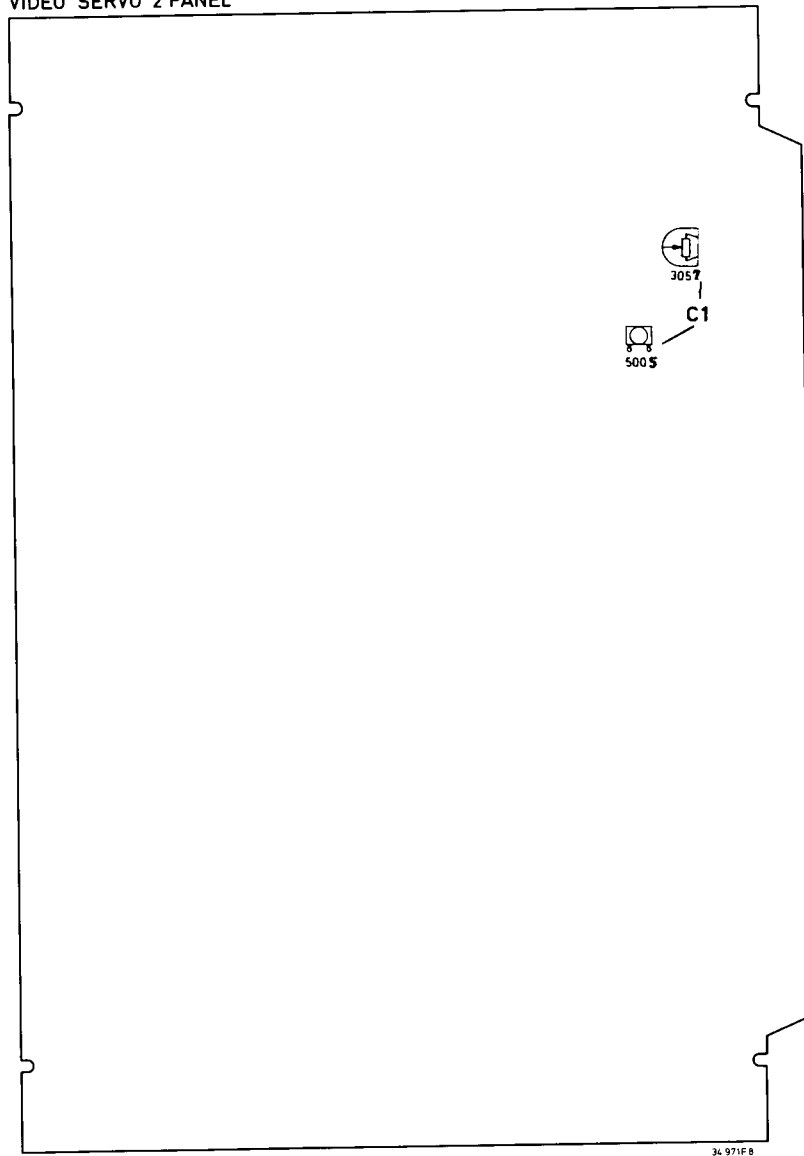

**Fig. 11**







**SUPPLY PANEL DIAGRAM A**

1001	B10	2010	A 8	2023	B 5	2041	C 6	2053	C 2	3011	C 8	3022	A 8	3034	A10	3055	B 5	3066	A 5	3077	
1003	B 9	2011	B 7	2024	B 6	2042	B 2	3001	B10	3012	C 9	3023	A 4	3035	A10	3056	B 5	3067	A 5	3078	
2001	C 9	2012	B 8	2025	C 1	2043	C 4	3002	B10	3013	A 7	3024	B 2	3036	A10	3057	A 5	3068	B 5	3079	
2002	B10	2013	A 8	2030	B 1	2045	C 4	3003	A10	3014	A 6	3026	B10	3041	A 7	3058	A 5	3069	B 4	3080	
2003	C 8	2014	B 9	2031	B 1	2046	C 2	3004	B10	3015	A 6	3027	A 2	3042	B 8	3059	C 5	3070	B 6	3081	
2004	C10	2015	C 8	2032	B 1	2047	C 2	3005	A 9	3016	A 6	3028	B 2	3043	A 7	3060	C 5	3071	B 6	3082	
2005	C10	2016	A 9	2033	A 4	2048	C 4	3006	B 8	3017	A 7	3029	A10	3044	A 8	3061	B 5	3072	B 1	3083	
2006	C 9	2017	B 8	2034	A 1	2049	C 3	3007	B 9	3018	A 7	3030	B 9	3045	A 7	3062	B 5	3073	B 1	3084	
2007	C 9	2020	B 6	2035	B 1	2050	C 4	3008	A10	3019	A 7	3031	B10	3046	A 7	3063	B 5	3074	C 1	3085	
2008	B10	2021	B 7	2036	A 4	2051	B 4	3009	B 8	3020	A 7	3032	B 9	3047	A 7	3064	B 5	3075	B 1	3086	
2009	A 9	2022	C 5	2037	A 6	2052	C 2	3010	C 8	3021	A 7	3033	A10	3048	A 2	3065	B 6	3076	A 1	3087	
																					3099

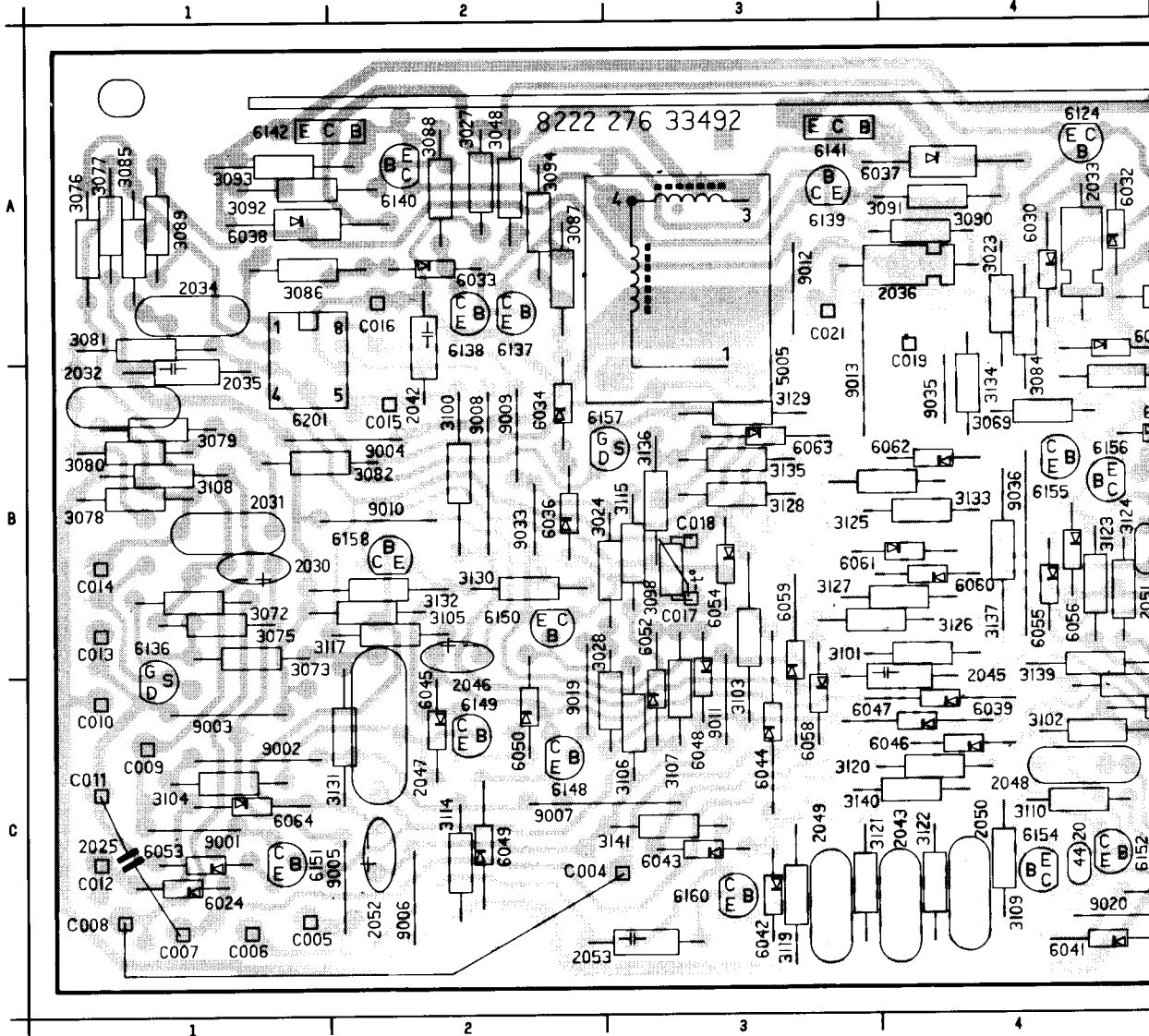

5	3077	A 1	3088	A 2	3103	C 3	3114	C 2	3125	B 3	3136	B 3	5006	A 9	6014	A 8	6033	A 2	6045	C 2	6057	B 5	6106	A 6	6124
5	3078	B 1	3089	A 1	3104	C 1	3115	B 3	3126	B 4	3137	B 4	6001	B 10	6015	A 8	6034	B 2	6046	C 4	6058	C 3	6107	A 6	6127
5	3079	B 1	3090	A 4	3105	B 2	3116	C 6	3127	B 3	3138	C 5	6002	B 9	6016	A 8	6036	B 2	6047	C 3	6059	B 3	6108	A 7	6128
3	3080	B 1	3091	A 4	3106	C 3	3117	B 2	3128	B 3	3139	C 4	6003	B 10	6019	B 5	6037	A 4	6048	C 3	6060	B 4	6109	A 6	6129
3	3081	A 1	3092	A 1	3107	C 3	3118	B 9	3129	B 3	3140	C 3	6005	A 8	6020	A 5	6038	A 1	6049	C 2	6061	B 3	6110	A 8	6130
3	3082	B 2	3093	A 1	3108	B 1	3119	C 3	3130	B 2	3141	C 3	6007	A 9	6021	B 6	6039	C 4	6050	C 2	6062	B 4	6115	A 9	6131
3	3083	B 5	3094	A 2	3109	C 4	3120	C 3	3131	C 2	5001	C 7	6008	A 10	6022	B 5	6040	C 6	6052	B 3	6063	B 3	6116	A 10	6136
3	3084	B 4	3095	C 6	3110	C 4	3121	C 3	3132	B 2	5002	C 9	6009	C 8	6023	C 5	6041	C 4	6053	C 1	6064	C 1	6117	A 10	6137
3	3085	A 1	3100	B 2	3111	C 5	3122	C 4	3133	B 4	5003	B 7	6010	A 6	6024	C 1	6042	C 3	6054	B 3	6102	A 10	6121	A 8	6138
3	3086	A 1	3101	B 3	3112	B 5	3123	B 4	3134	B 4	5004	B 7	6011	A 7	6030	A 4	6043	C 3	6055	B 4	6104	C 8	6122	B 8	6139
3	3087	A 2	3102	C 4	3113	C 5	3124	B 4	3135	B 3	5005	B 3	6012	A 9	6031	A 5	6044	C 3	6056	B 4	6105	A 7	6123	A 7	6140
3	3098	B 3											6013	B 9	6032	A 4									

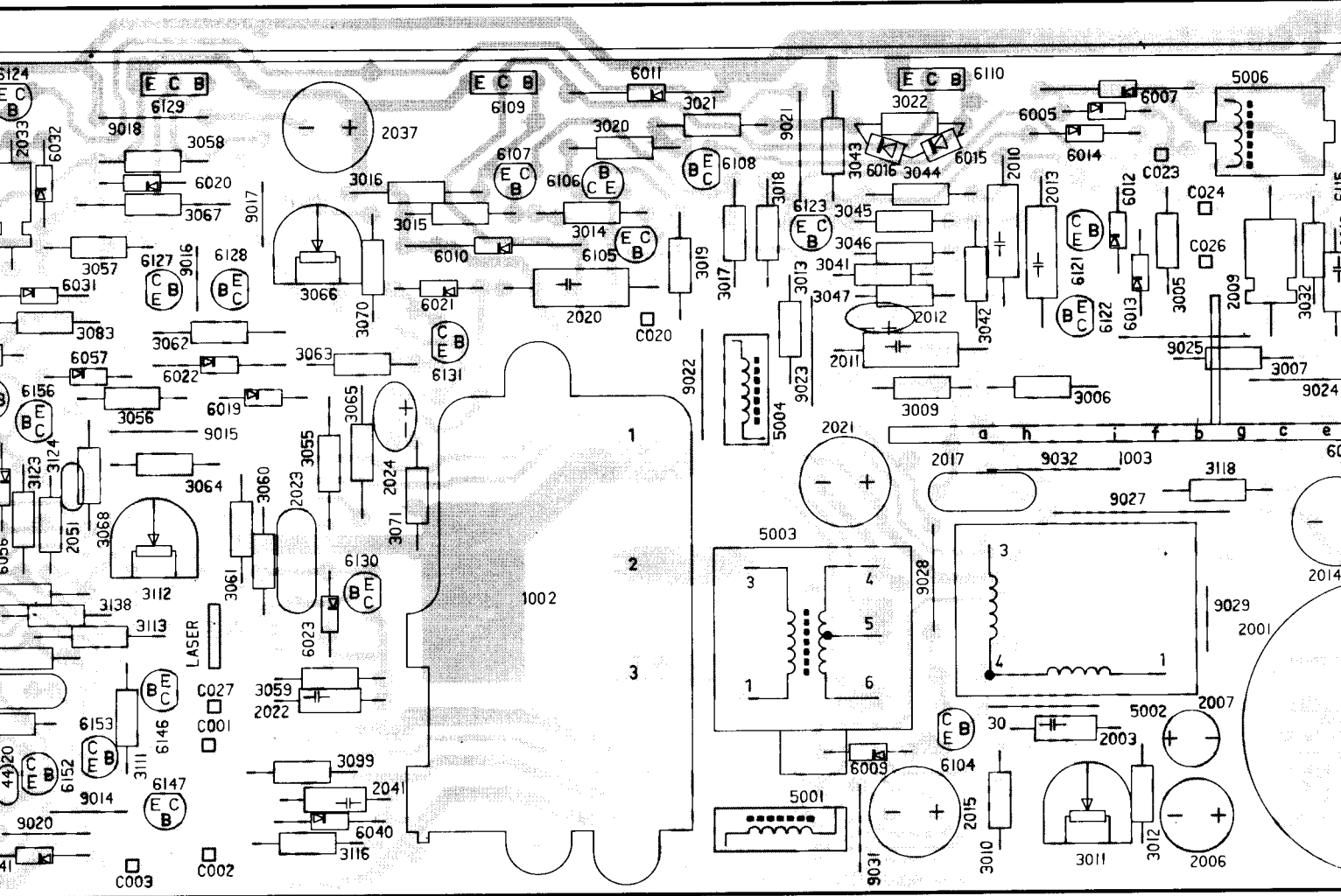

A 6	6124	A 4	6141	A 3	6155	B 4
A 6	6127	A 5	6142	A 1	6156	B 4
A 7	6128	A 5	6146	C 5	6157	B 3
A 6	6129	A 5	6147	C 5	6158	B 2
A 8	6130	B 6	6148	C 2	6160	C 3
A 9	6131	B 6	6149	C 2	6201	B 1
A10	6136	B 1	6150	B 2		
A10	6137	A 2	6151	C 1		
A 8	6138	A 2	6152	C 4		
B 8	6139	A 3	6153	C 5		
A 7	6140	A 2	6154	C 4		

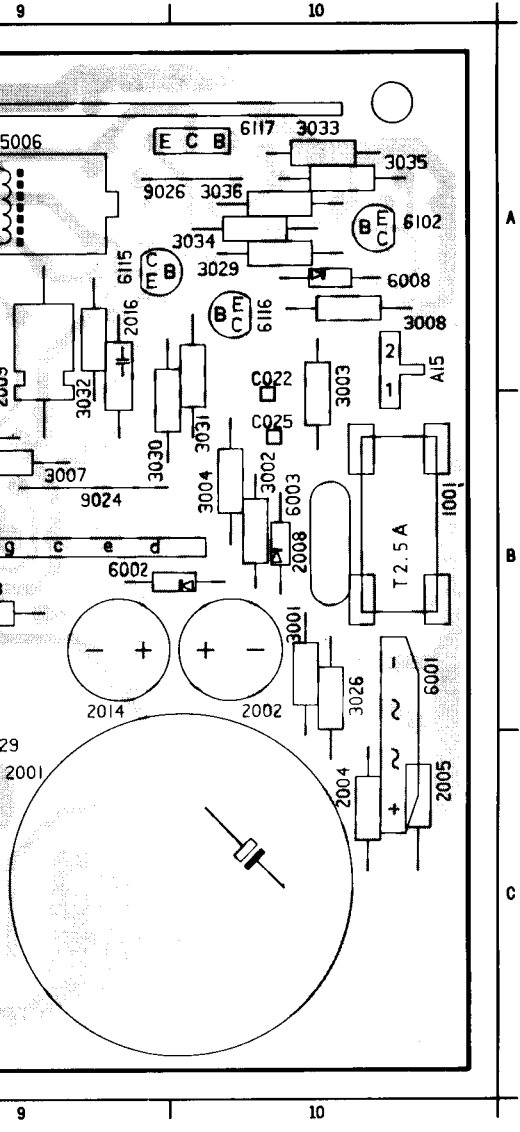

**SUB SUPPLY PANEL**

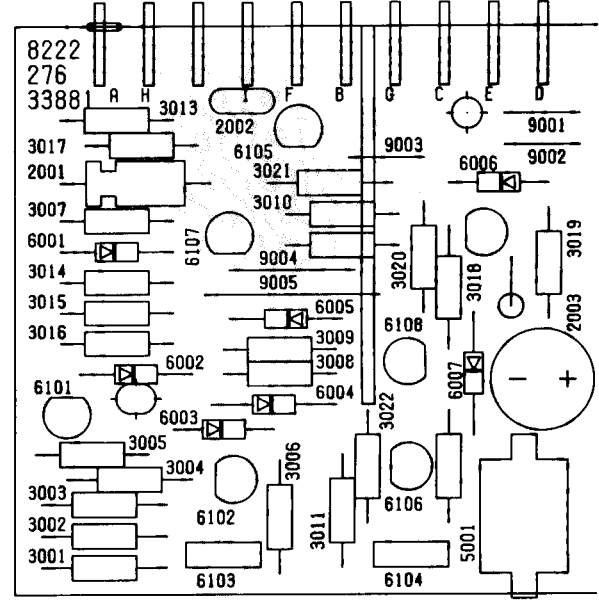

32485D4

# AUDIO DEMOD PANEL DIAGRAM B'

1005	A 6	2023	G 6	2058	D 5	2091	F 3	2169	G 7	2201	C 10	2231	F 12	3011	E 5	3036	G 7	3064	C 6	3094	C 6	3116	F 4	3150	E 2	3193	D 4	3227	F 6	3248	E 8	3271	F 8	3292	F 8	3313	F 8	3334	F 8	3355	F 8	3376	F 8	3397	F 8	3418	F 8	3439	F 8	3460	F 8	3481	F 8	3502	F 8	3523	F 8	3544	F 8	3565	F 8	3586	F 8	3607	F 8	3628	F 8	3649	F 8	3670	F 8	3691	F 8	3712	F 8	3733	F 8	3754	F 8	3775	F 8	3796	F 8	3817	F 8	3838	F 8	3859	F 8	3880	F 8	3901	F 8	3922	F 8	3943	F 8	3964	F 8	3985	F 8	4006	F 8	4027	F 8	4048	F 8	4069	F 8	4090	F 8	4111	F 8	4132	F 8	4153	F 8	4174	F 8	4195	F 8	4216	F 8	4237	F 8	4258	F 8	4279	F 8	4300	F 8	4321	F 8	4342	F 8	4363	F 8	4384	F 8	4405	F 8	4426	F 8	4447	F 8	4468	F 8	4489	F 8	4510	F 8	4531	F 8	4552	F 8	4573	F 8	4594	F 8	4615	F 8	4636	F 8	4657	F 8	4678	F 8	4699	F 8	4720	F 8	4741	F 8	4762	F 8	4783	F 8	4804	F 8	4825	F 8	4846	F 8	4867	F 8	4888	F 8	4909	F 8	4930	F 8	4951	F 8	4972	F 8	4993	F 8	5014	F 8	5035	F 8	5056	F 8	5077	F 8	5098	F 8	5119	F 8	5140	F 8	5161	F 8	5182	F 8	5203	F 8	5224	F 8	5245	F 8	5266	F 8	5287	F 8	5308	F 8	5329	F 8	5350	F 8	5371	F 8	5392	F 8	5413	F 8	5434	F 8	5455	F 8	5476	F 8	5497	F 8	5518	F 8	5539	F 8	5560	F 8	5581	F 8	5602	F 8	5623	F 8	5644	F 8	5665	F 8	5686	F 8	5707	F 8	5728	F 8	5749	F 8	5770	F 8	5791	F 8	5812	F 8	5833	F 8	5854	F 8	5875	F 8	5896	F 8	5917	F 8	5938	F 8	5959	F 8	5980	F 8	6001	F 8	6022	F 8	6043	F 8	6064	F 8	6085	F 8	6106	F 8	6127	F 8	6148	F 8	6169	F 8	6190	F 8	6211	F 8	6232	F 8	6253	F 8	6274	F 8	6295	F 8	6316	F 8	6337	F 8	6358	F 8	6379	F 8	6400	F 8	6421	F 8	6442	F 8	6463	F 8	6484	F 8	6505	F 8	6526	F 8	6547	F 8	6568	F 8	6589	F 8	6610	F 8	6631	F 8	6652	F 8	6673	F 8	6694	F 8	6715	F 8	6736	F 8	6757	F 8	6778	F 8	6799	F 8	6820	F 8	6841	F 8	6862	F 8	6883	F 8	6904	F 8	6925	F 8	6946	F 8	6967	F 8	6988	F 8	7009	F 8	7030	F 8	7051	F 8	7072	F 8	7093	F 8	7114	F 8	7135	F 8	7156	F 8	7177	F 8	7198	F 8	7219	F 8	7240	F 8	7261	F 8	7282	F 8	7303	F 8	7324	F 8	7345	F 8	7366	F 8	7387	F 8	7408	F 8	7429	F 8	7450	F 8	7471	F 8	7492	F 8	7513	F 8	7534	F 8	7555	F 8	7576	F 8	7597	F 8	7618	F 8	7639	F 8	7660	F 8	7681	F 8	7702	F 8	7723	F 8	7744	F 8	7765	F 8	7786	F 8	7807	F 8	7828	F 8	7849	F 8	7870	F 8	7891	F 8	7912	F 8	7933	F 8	7954	F 8	7975	F 8	7996	F 8	8017	F 8	8038	F 8	8059	F 8	8080	F 8	8101	F 8	8122	F 8	8143	F 8	8164	F 8	8185	F 8	8206	F 8	8227	F 8	8248	F 8	8269	F 8	8290	F 8	8311	F 8	8332	F 8	8353	F 8	8374	F 8	8395	F 8	8416	F 8	8437	F 8	8458	F 8	8479	F 8	8500	F 8	8521	F 8	8542	F 8	8563	F 8	8584	F 8	8605	F 8	8626	F 8	8647	F 8	8668	F 8	8689	F 8	8710	F 8	8731	F 8	8752	F 8	8773	F 8	8794	F 8	8815	F 8	8836	F 8	8857	F 8	8878	F 8	8899	F 8	8920	F 8	8941	F 8	8962	F 8	8983	F 8	9004	F 8	9025	F 8	9046	F 8	9067	F 8	9088	F 8	9109	F 8	9130	F 8	9151	F 8	9172	F 8	9193	F 8	9214	F 8	9235	F 8	9256	F 8	9277	F 8	9298	F 8	9319	F 8	9340	F 8	9361	F 8	9382	F 8	9403	F 8	9424	F 8	9445	F 8	9466	F 8	9487	F 8	9508	F 8	9529	F 8	9550	F 8	9571	F 8	9592	F 8	9613	F 8	9634	F 8	9655	F 8	9676	F 8	9697	F 8	9718	F 8	9739	F 8	9760	F 8	9781	F 8	9802	F 8	9823	F 8	9844	F 8	9865	F 8	9886	F 8	9907	F 8	9928	F 8	9949	F 8	9970	F 8	9991	F 8	10000	F 8
------	-----	------	-----	------	-----	------	-----	------	-----	------	------	------	------	------	-----	------	-----	------	-----	------	-----	------	-----	------	-----	------	-----	------	-----	------	-----	------	-----	------	-----	------	-----	------	-----	------	-----	------	-----	------	-----	------	-----	------	-----	------	-----	------	-----	------	-----	------	-----	------	-----	------	-----	------	-----	------	-----	------	-----	------	-----	------	-----	------	-----	------	-----	------	-----	------	-----	------	-----	------	-----	------	-----	------	-----	------	-----	------	-----	------	-----	------	-----	------	-----	------	-----	------	-----	------	-----	------	-----	------	-----	------	-----	------	-----	------	-----	------	-----	------	-----	------	-----	------	-----	------	-----	------	-----	------	-----	------	-----	------	-----	------	-----	------	-----	------	-----	------	-----	------	-----	------	-----	------	-----	------	-----	------	-----	------	-----	------	-----	------	-----	------	-----	------	-----	------	-----	------	-----	------	-----	------	-----	------	-----	------	-----	------	-----	------	-----	------	-----	------	-----	------	-----	------	-----	------	-----	------	-----	------	-----	------	-----	------	-----	------	-----	------	-----	------	-----	------	-----	------	-----	------	-----	------	-----	------	-----	------	-----	------	-----	------	-----	------	-----	------	-----	------	-----	------	-----	------	-----	------	-----	------	-----	------	-----	------	-----	------	-----	------	-----	------	-----	------	-----	------	-----	------	-----	------	-----	------	-----	------	-----	------	-----	------	-----	------	-----	------	-----	------	-----	------	-----	------	-----	------	-----	------	-----	------	-----	------	-----	------	-----	------	-----	------	-----	------	-----	------	-----	------	-----	------	-----	------	-----	------	-----	------	-----	------	-----	------	-----	------	-----	------	-----	------	-----	------	-----	------	-----	------	-----	------	-----	------	-----	------	-----	------	-----	------	-----	------	-----	------	-----	------	-----	------	-----	------	-----	------	-----	------	-----	------	-----	------	-----	------	-----	------	-----	------	-----	------	-----	------	-----	------	-----	------	-----	------	-----	------	-----	------	-----	------	-----	------	-----	------	-----	------	-----	------	-----	------	-----	------	-----	------	-----	------	-----	------	-----	------	-----	------	-----	------	-----	------	-----	------	-----	------	-----	------	-----	------	-----	------	-----	------	-----	------	-----	------	-----	------	-----	------	-----	------	-----	------	-----	------	-----	------	-----	------	-----	------	-----	------	-----	------	-----	------	-----	------	-----	------	-----	------	-----	------	-----	------	-----	------	-----	------	-----	------	-----	------	-----	------	-----	------	-----	------	-----	------	-----	------	-----	------	-----	------	-----	------	-----	------	-----	------	-----	------	-----	------	-----	------	-----	------	-----	------	-----	------	-----	------	-----	------	-----	------	-----	------	-----	------	-----	------	-----	------	-----	------	-----	------	-----	------	-----	------	-----	------	-----	------	-----	------	-----	------	-----	------	-----	------	-----	------	-----	------	-----	------	-----	------	-----	------	-----	------	-----	------	-----	------	-----	------	-----	------	-----	------	-----	------	-----	------	-----	------	-----	------	-----	------	-----	------	-----	------	-----	------	-----	------	-----	------	-----	------	-----	------	-----	------	-----	------	-----	------	-----	------	-----	------	-----	------	-----	------	-----	------	-----	------	-----	------	-----	------	-----	------	-----	------	-----	------	-----	------	-----	------	-----	------	-----	------	-----	------	-----	------	-----	------	-----	------	-----	------	-----	------	-----	------	-----	------	-----	------	-----	------	-----	------	-----	------	-----	------	-----	------	-----	------	-----	------	-----	------	-----	------	-----	------	-----	------	-----	------	-----	------	-----	------	-----	------	-----	------	-----	------	-----	------	-----	------	-----	------	-----	------	-----	------	-----	------	-----	------	-----	------	-----	------	-----	------	-----	------	-----	------	-----	------	-----	------	-----	------	-----	------	-----	-------	-----

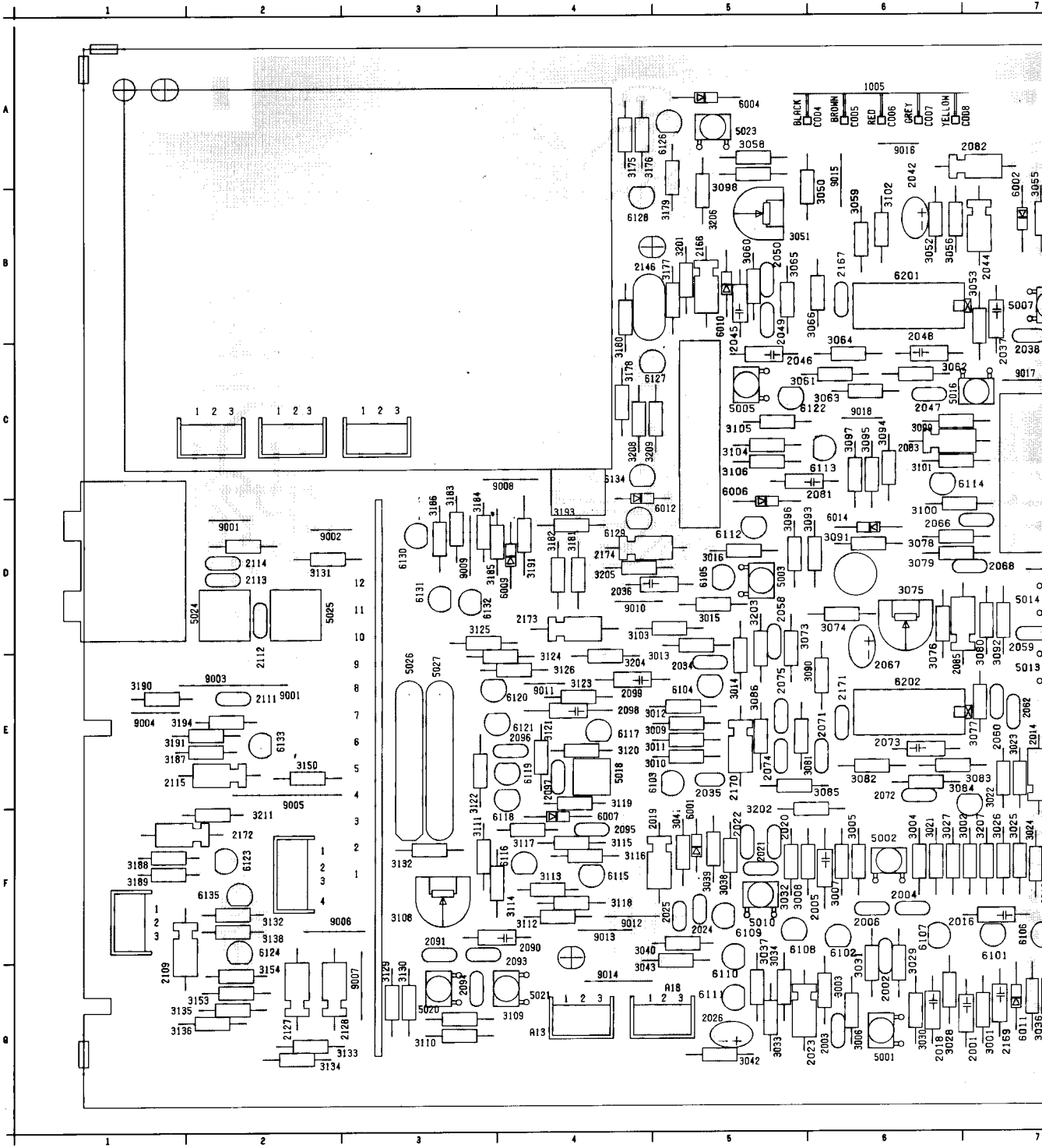



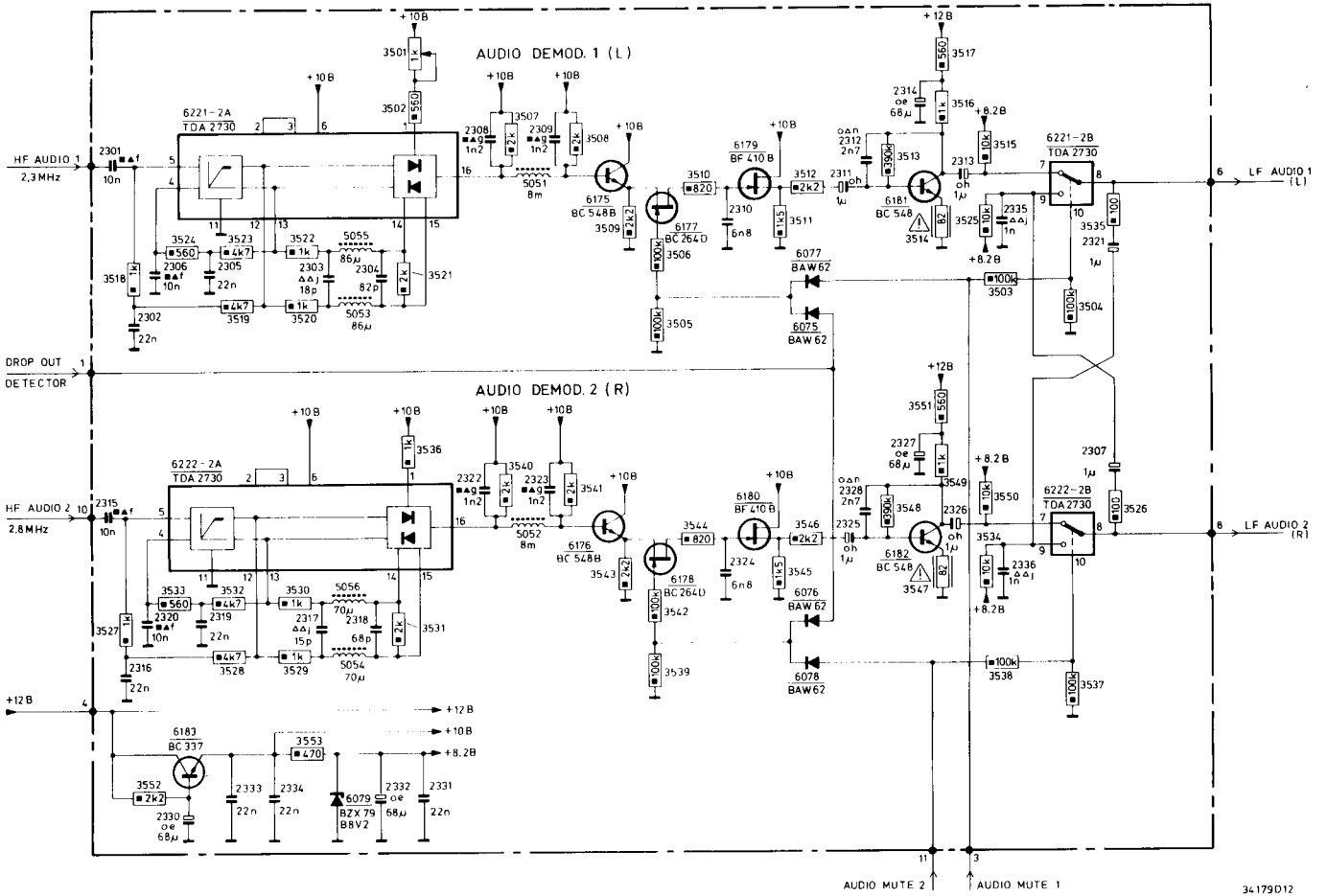

3c179D12

2301	B 1	2310	C 2	2319	C 4	2328	C 5	2351	B 6	3504	B 2	3513	B 2	3522	B 1	3531	B 4	3540	C 4	3549	C 5	3564	B 7	3573	C 7	5056	B 4	6177	C 2	6192	C 7
2302	B 1	2311	B 2	2320	C 4	2330	C 3	2352	B 6	3505	C 2	3514	B 3	3523	B 1	3532	B 3	3541	B 4	3550	B 4	3565	C 6	3574	C 7	6075	C 3	6178	C 4	6221	B 2
2303	A 1	2312	B 2	2321	B 5	2331	C 3	2353	B 6	3506	C 2	3515	B 2	3524	C 1	3533	C 3	3542	C 4	3551	C 3	3566	C 6	3575	B 7	6076	C 4	6179	B 2	6222	B 4
2304	A 1	2313	B 3	2322	C 4	2332	A 5	2354	C 7	3507	C 1	3516	B 3	3525	C 3	3534	B 4	3543	C 5	3552	C 6	3567	C 6	3576	B 7	6077	B 2	6180	C 4		
2305	C 1	2314	C 3	2323	C 4	2333	B 1	2355	A 7	3508	C 2	3517	B 3	3526	C 3	3535	B 4	3544	C 5	3553	B 3	3568	C 6	3577	B 7	6078	A 5	6181	A 3		
2306	C 1	2315	B 4	2324	C 5	2334	B 4	2356	B 7	3509	B 1	3518	B 1	3527	B 4	3536	B 4	3545	C 5	3554	C 6	3569	C 6	3578	B 7	6079	C 3	6182	B 5		
2307	B 3	2316	C 3	2325	C 6	2335	B 3	3501	C 2	3510	B 2	3519	B 1	3528	B 3	3537	B 4	3546	C 5	3555	C 6	3570	C 7	3579	A 2	6090	B 7	6183	A 3		
2308	C 1	2317	A 4	2326	C 5	2336	B 5	3502	B 1	3511	C 2	3520	B 1	3529	B 3	3538	B 4	3547	C 5	3556	C 6	3571	C 7	3580	A 4	6175	C 2	6186	B 7		
2309	C 1	2318	B 4	2327	C 5	2330	B 6	3503	A 2	3512	B 2	3521	A 1	3530	B 3	3539	C 5	3548	C 5	3557	C 6	3572	C 7	3581	B 2	6176	C 4	6191	C 7		

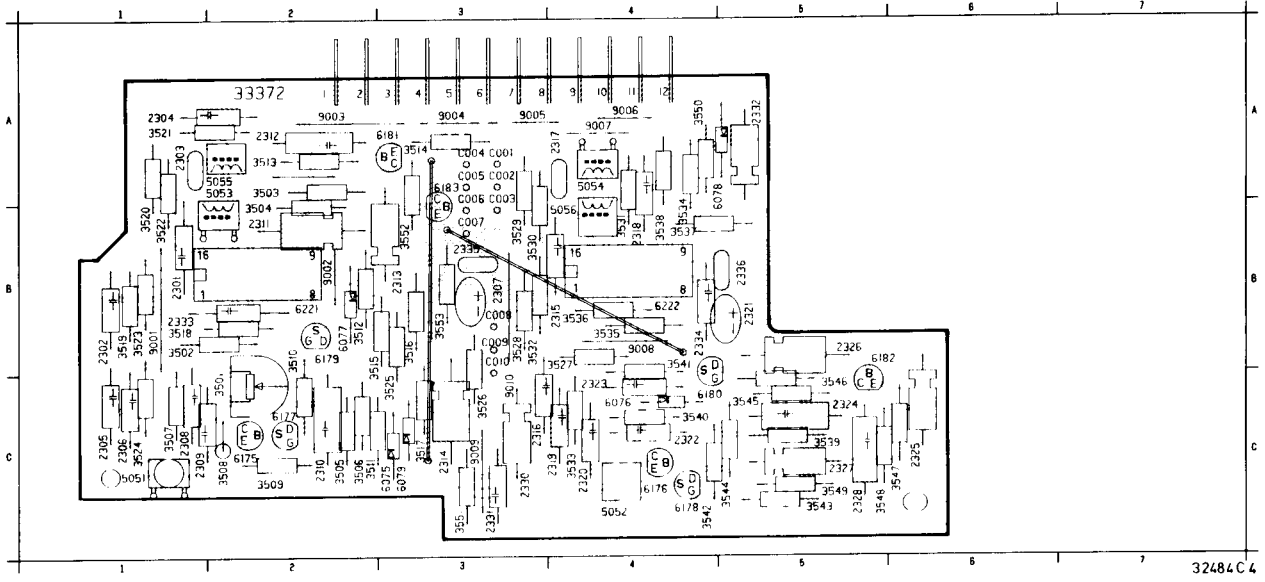

32484C4

# VIDEO SERVO 1 PANEL DIAGRAM B

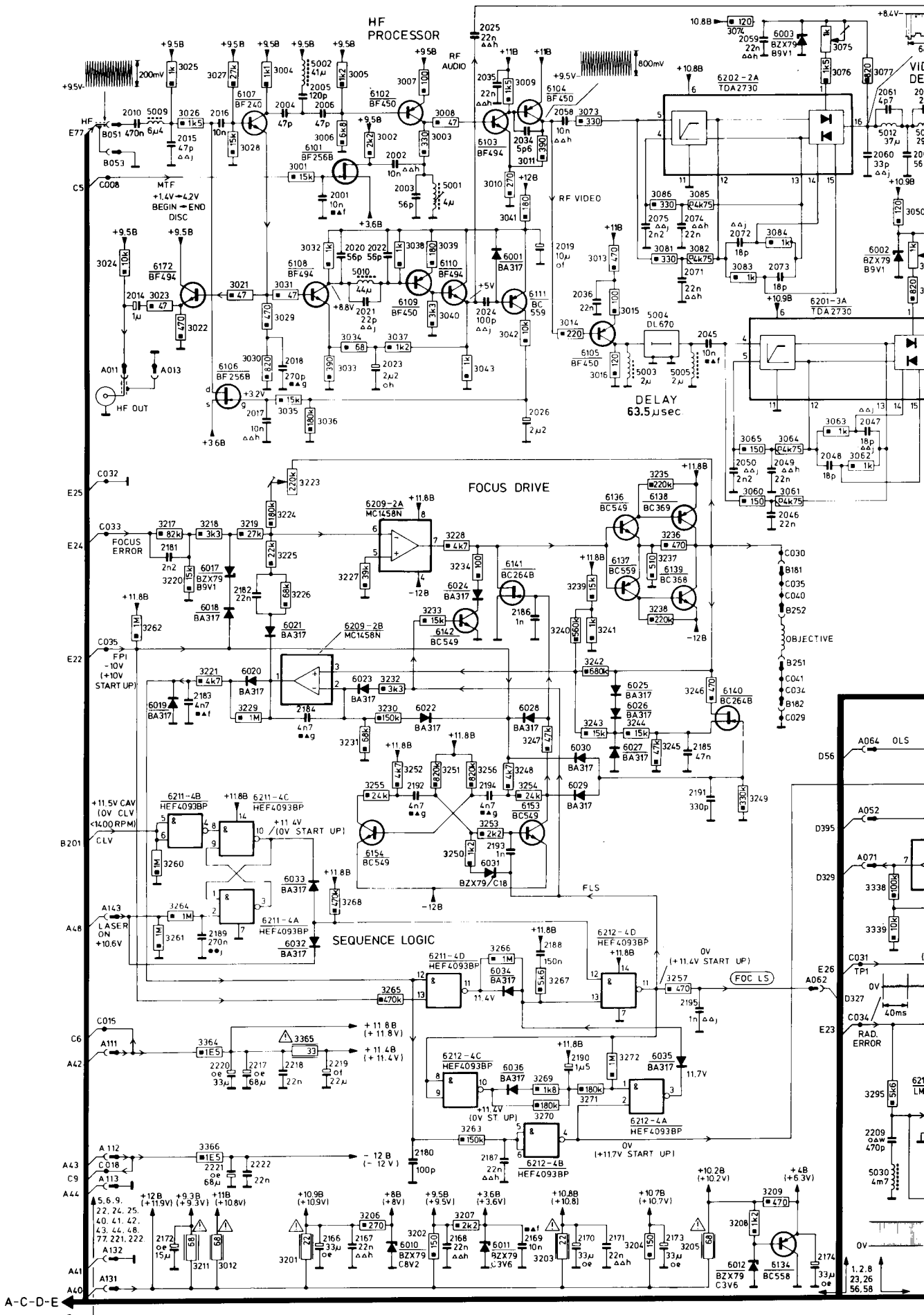

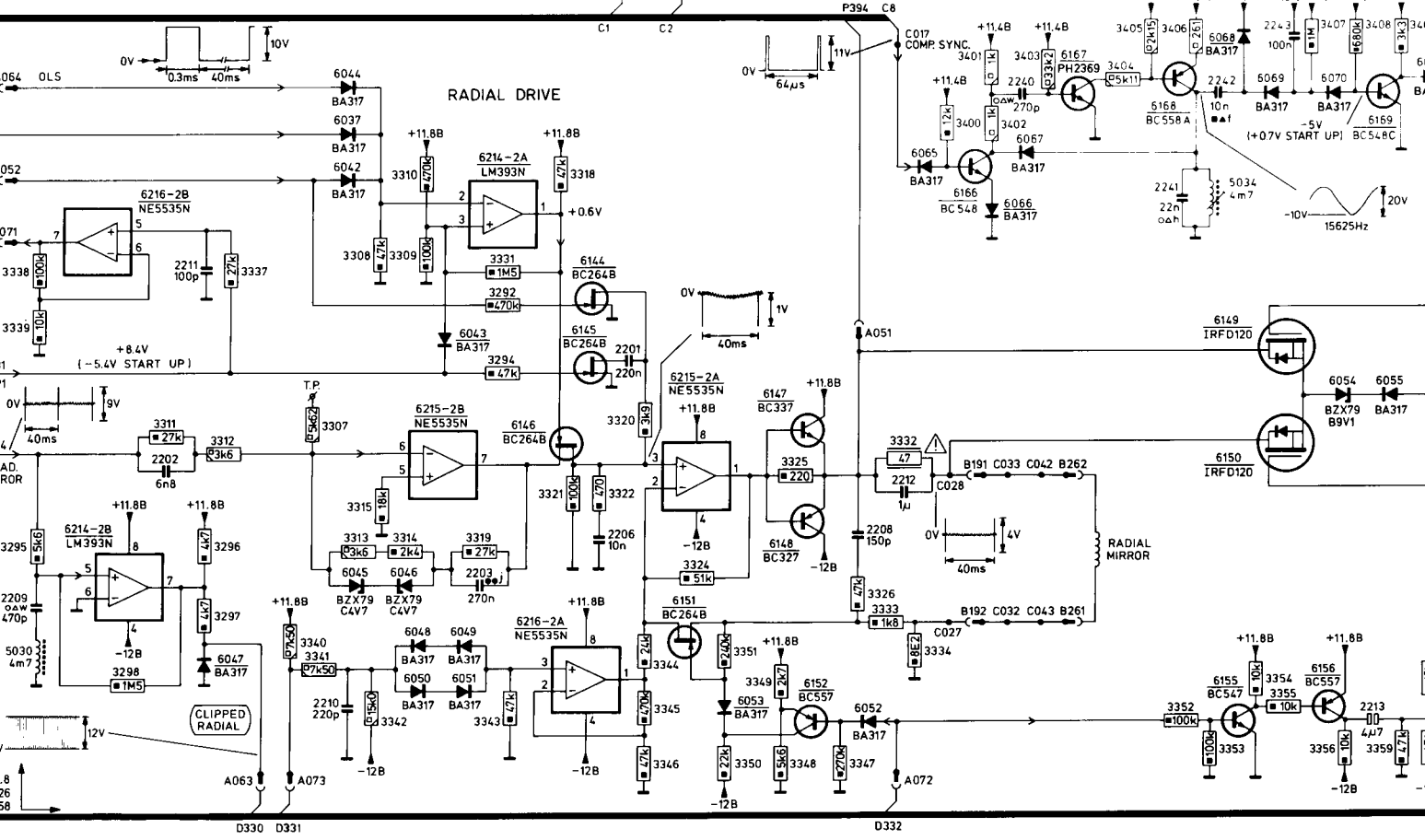
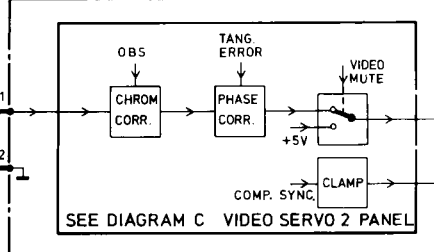
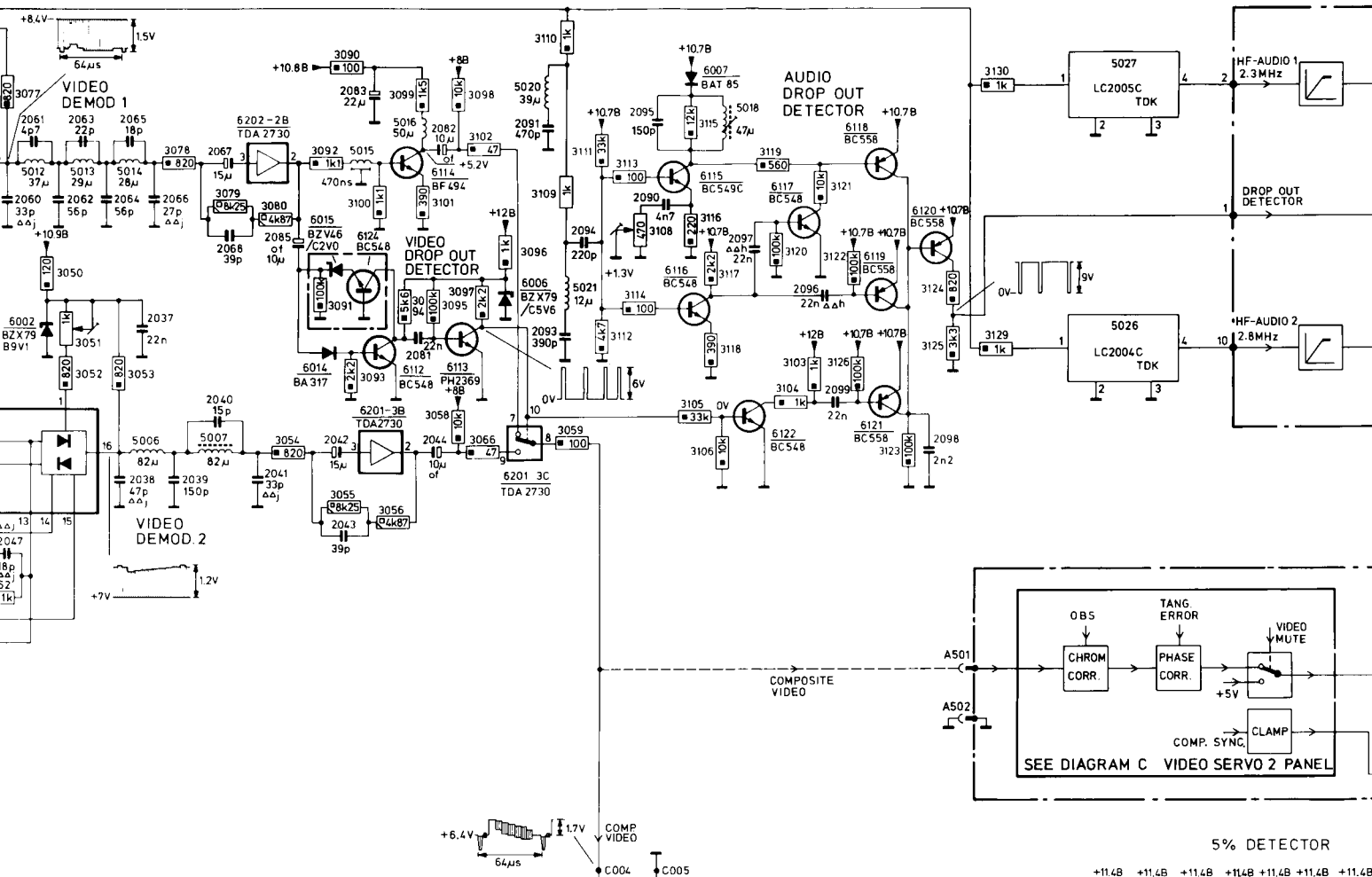



SEE DIAGRAM B'

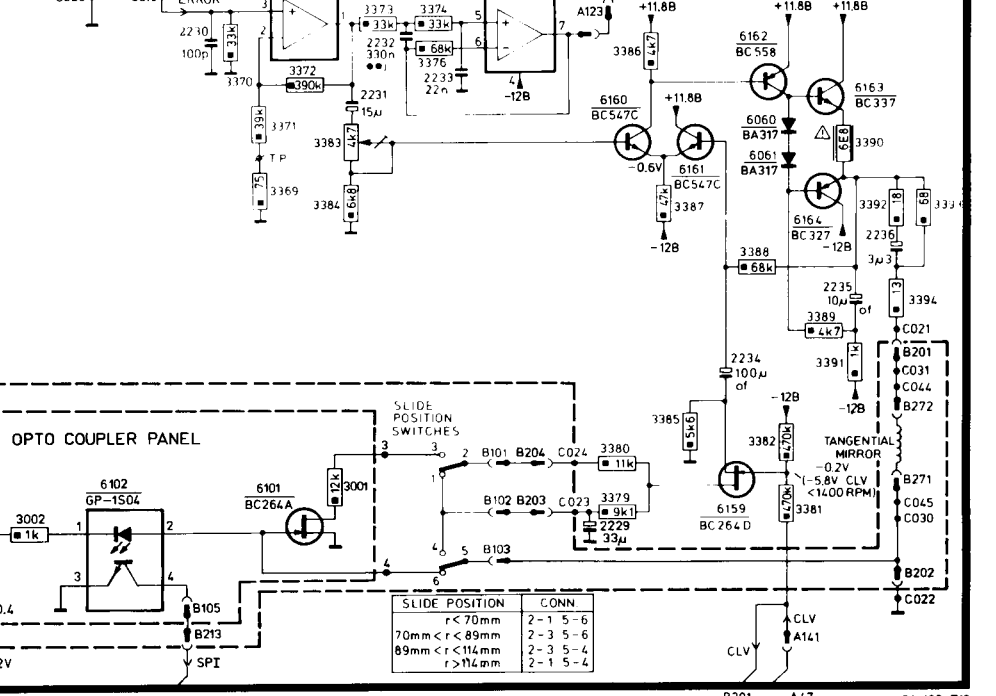
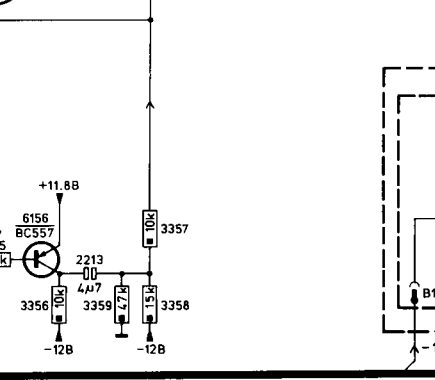
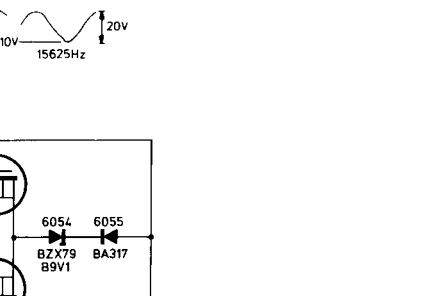
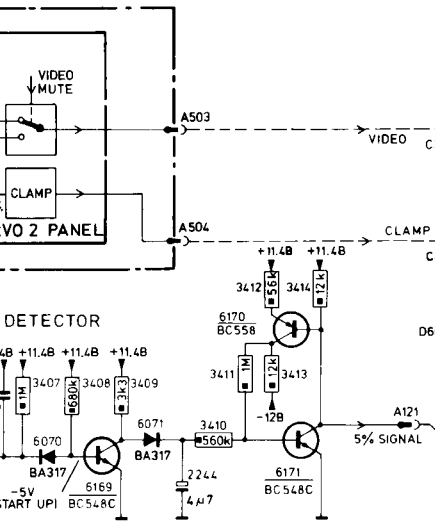
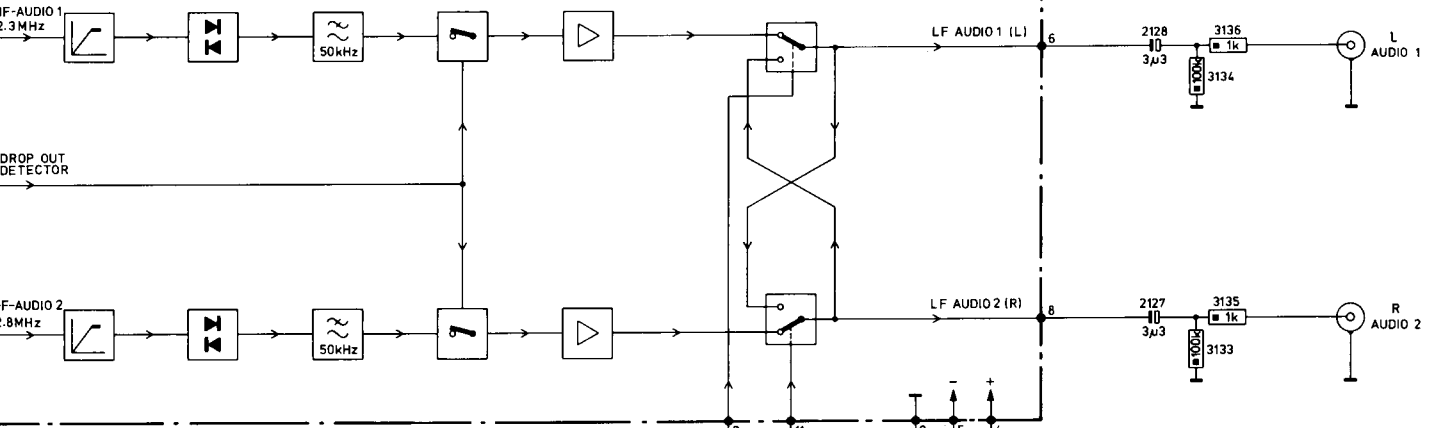

SLIDE POSITION	CONN
r < 70mm	2-1 5-6
70mm < r < 89mm	2-3 5-6
89mm < r < 114mm	2-3 5-4
r > 114mm	2-1 5-4

VIDEO SERVO 2 PANEL DIAGRAM C

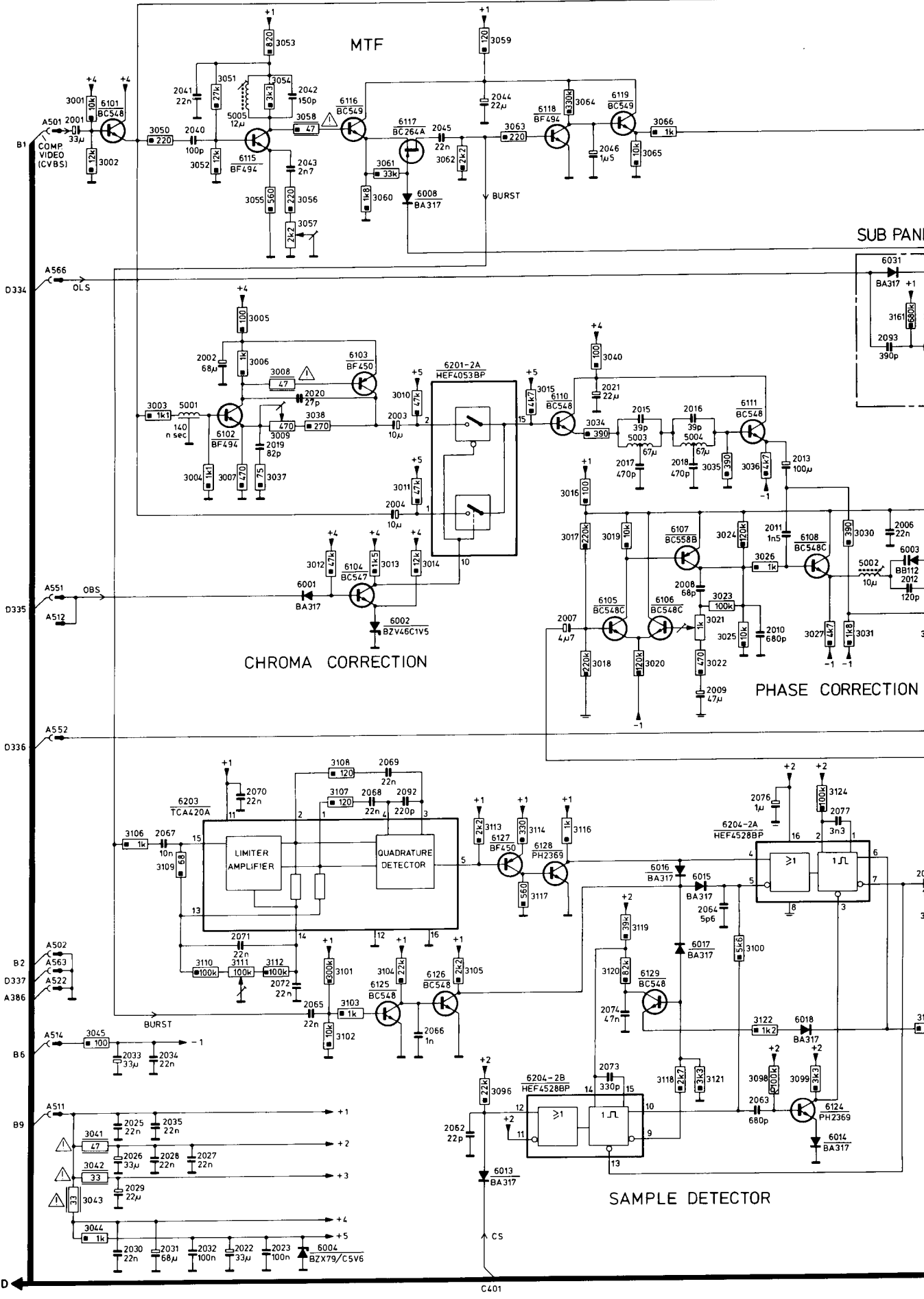

SUB PANEL

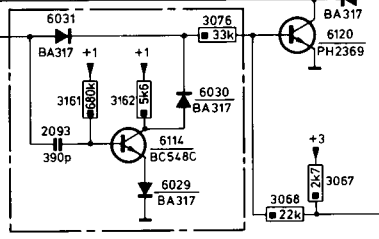

CORRECTION

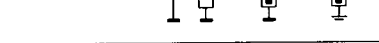

TANGENTIAL PHASE DETECTOR



FRAME SYNC SEPARATOR

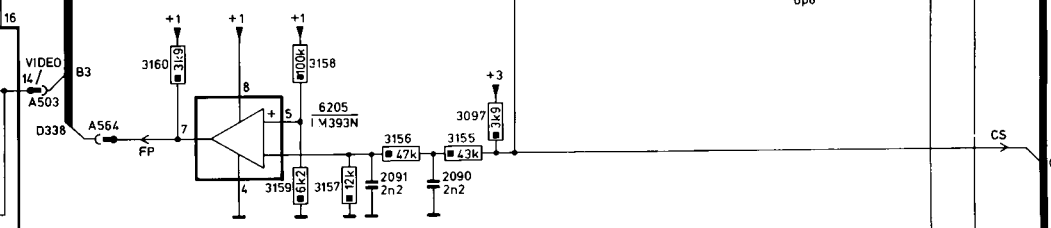

REF CONTROL

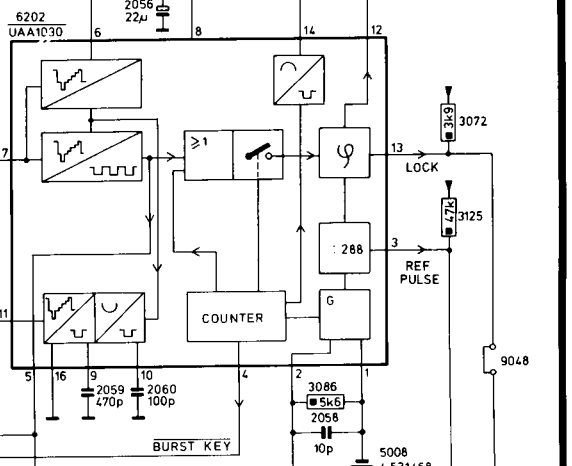

TANG. LOOP SWITCH

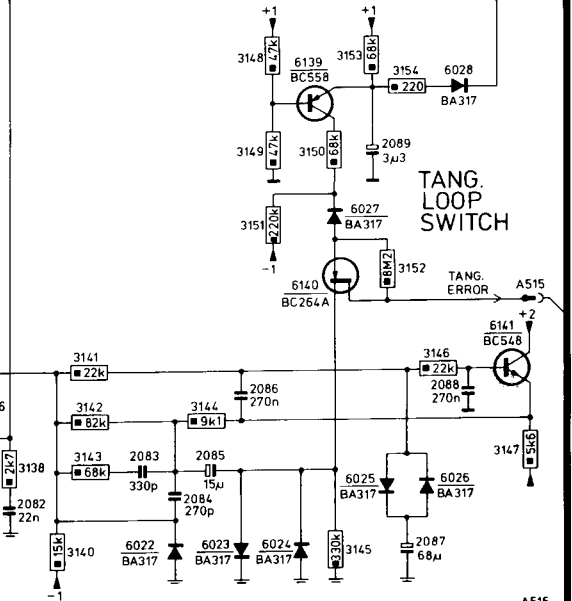

# VIDEO SERVO 2 PANEL DIAGRAM C

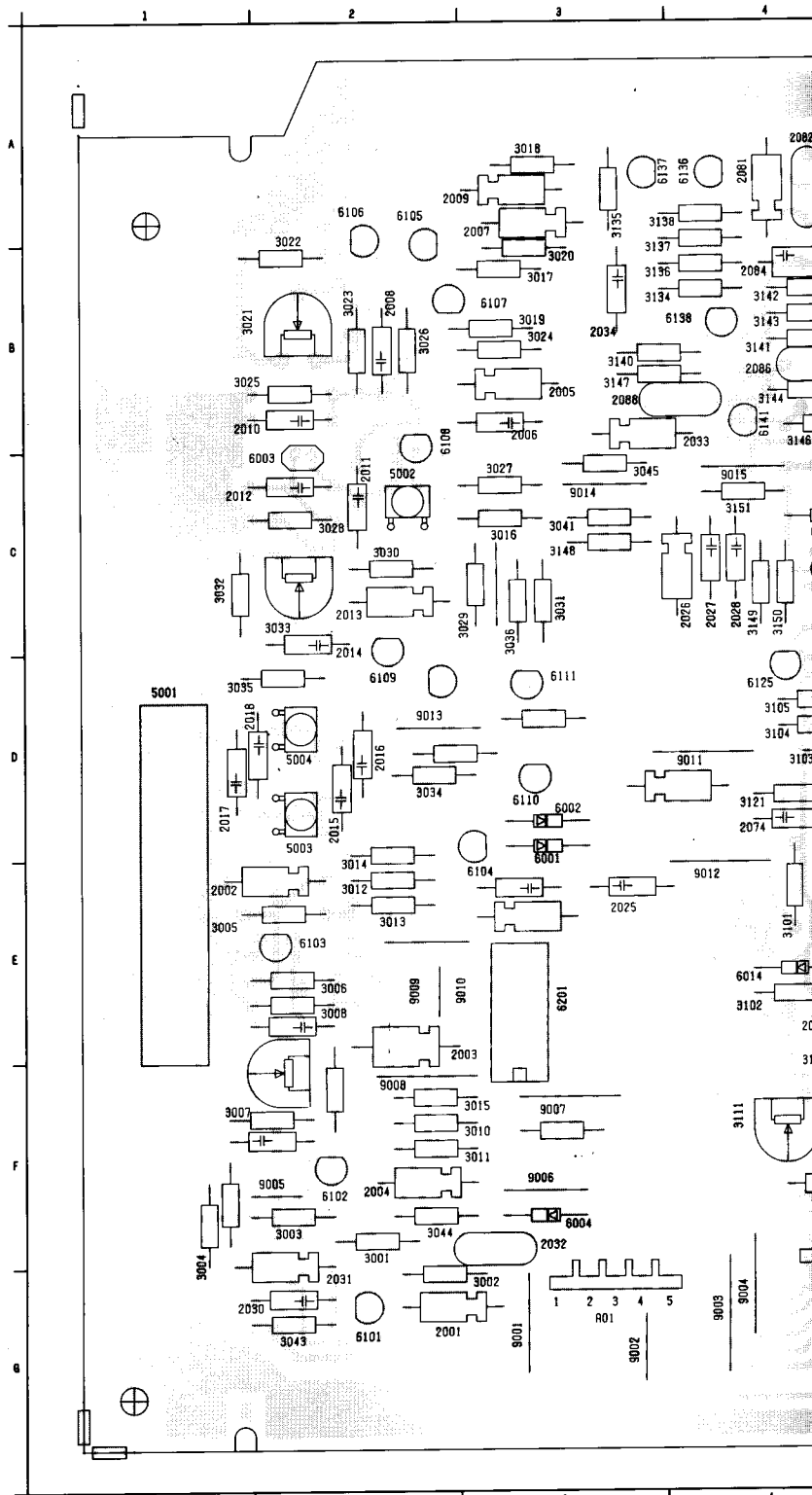

2001	G 2	2015	D 2	2040	F 8	2054	C 8	2068	E 5	2082	R 4	3005	E 1	3020	R 3	3034	D 2	3056	E 9
2002	E 1	2016	D 2	2041	F 8	2055	B 8	2069	E 6	2083	B 5	3006	E 2	3021	R 1	3035	D 1	3057	E 9
2003	F 3	2017	D 1	2042	F 7	2056	C 7	2070	F 6	2084	B 4	3007	F 1	3022	A 2	3036	C 3	3058	E 8
2004	F 2	2018	D 1	2043	F 8	2057	B 7	2071	F 5	2085	B 5	3008	E 2	3023	B 2	3041	C 3	3059	E 6
2005	B 3	2025	E 3	2044	E 8	2058	B 8	2072	F 4	2086	B 4	3010	F 3	3024	B 3	3042	C 7	3060	D 7
2006	B 3	2026	C 4	2045	E 7	2059	C 9	2073	E 5	2087	B 5	3011	F 3	3025	B 1	3043	F 2	3061	D 8
2007	R 3	2027	C 4	2046	E 7	2060	C 9	2074	D 4	2088	B 9	3012	E 2	3026	B 2	3044	F 2	3062	E 7
2008	B 2	2028	C 4	2047	D 8	2061	A 8	2075	O 6	2089	O 6	3013	E 2	3027	C 3	3045	C 3	3063	E 7
2009	R 3	2029	B 7	2048	E 9	2062	C 5	2076	E 5	2090	D 9	3014	E 2	3028	C 2	3050	F 7	3064	E 8
2010	B 1	2030	G 1	2049	B 9	2063	D 5	2077	E 5	2091	D 9	3015	F 3	3029	C 3	3051	E 7	3065	F 7
2011	C 2	2031	G 2	2050	A 9	2064	D 6	2078	C 5	2092	C 3	3016	B 3	3030	C 2	3052	F 6	3066	F 7
2012	C 1	2032	F 3	2051	A 8	2065	E 4	2079	B 5	3002	G 3	3017	B 3	3031	C 3	3053	F 6	3067	C 8
2013	C 2	2033	B 4	2052	B 8	2066	C 5	2080	A 5	3003	F 2	3018	A 3	3032	C 1	3054	F 7	3068	D 7
2014	C 2	2034	B 3	2053	B 9	2067	F 5	2081	A 4	3004	F 1	3019	B 3	3033	C 2	3055	F 8	3069	D 7



CONTROL 1 PANEL DIAGRAM D

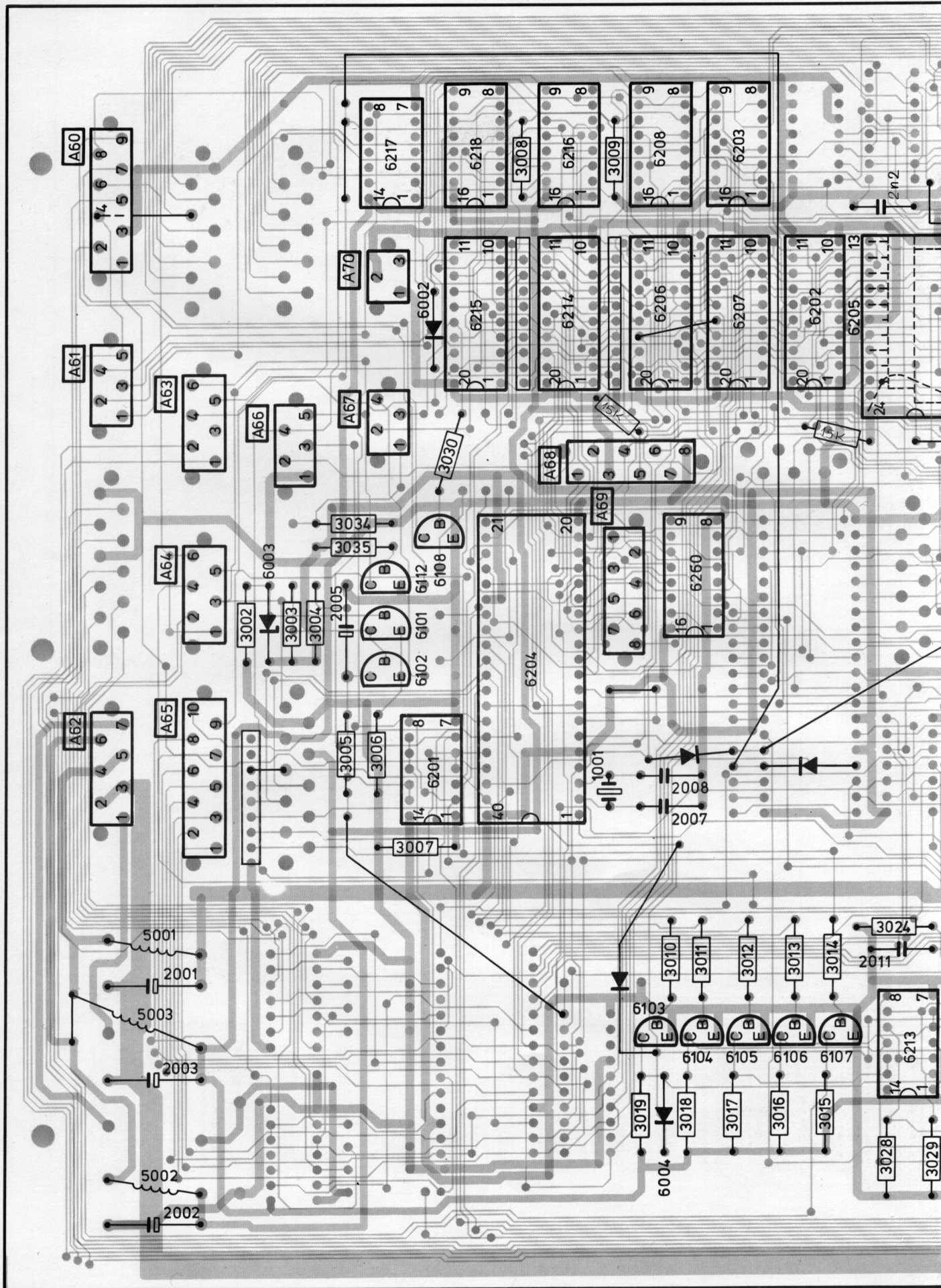

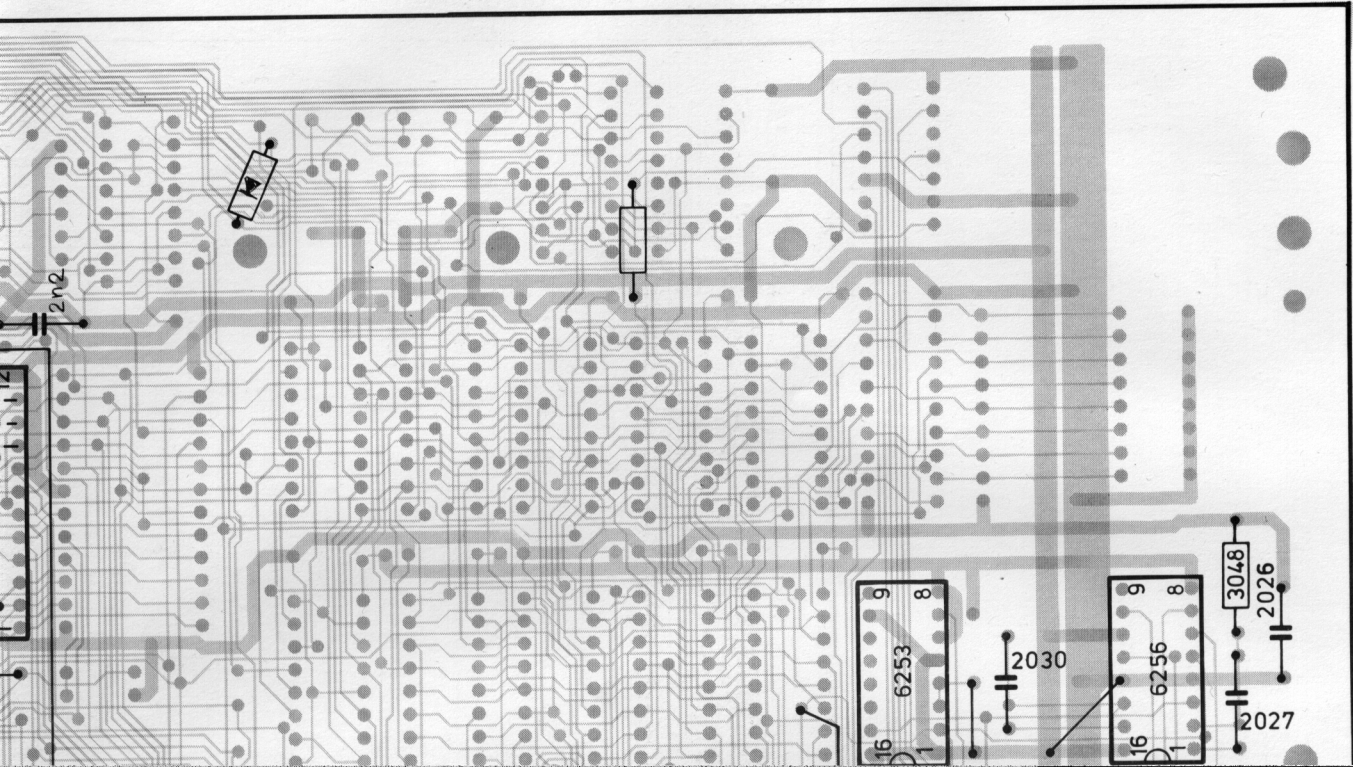

2n2

16 6253 1 8 9

2030

16 6256 1 8 9

3048 2026 2027

# CONTROL 1 PANEL DIAGRAM D

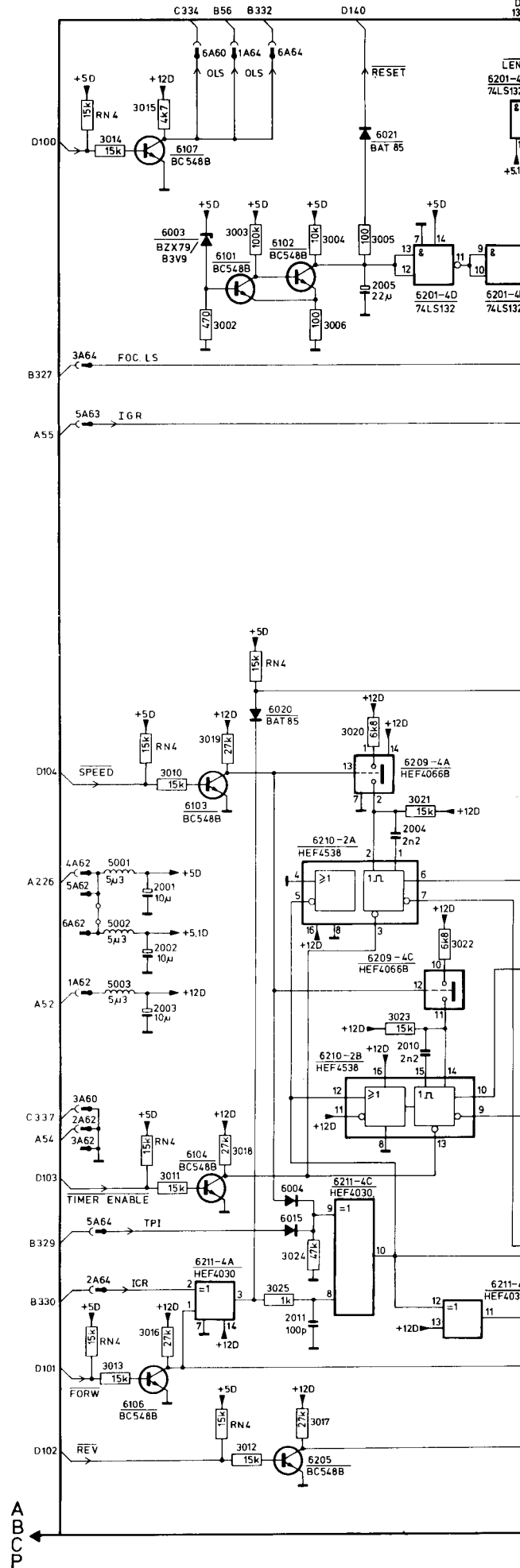



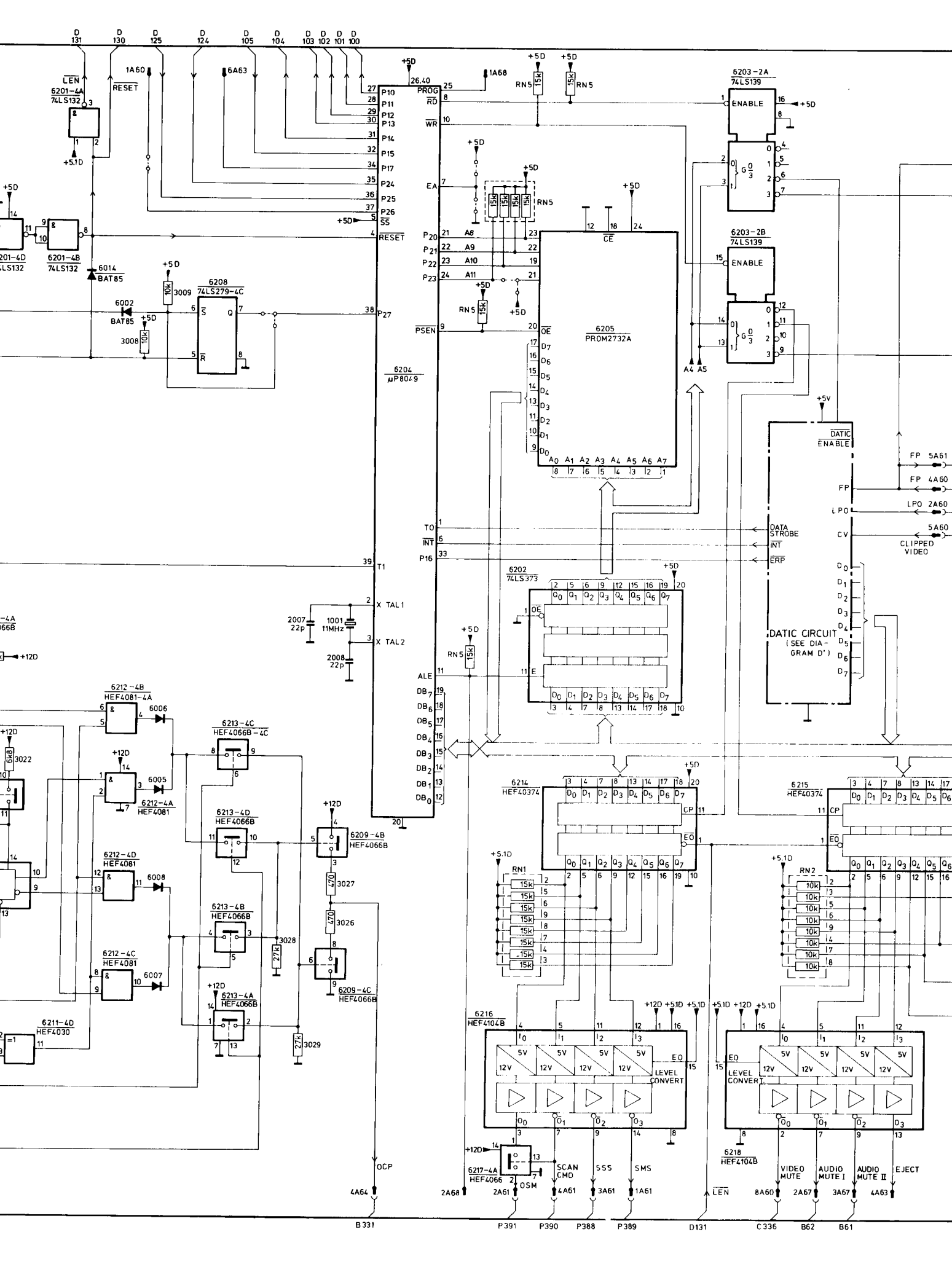

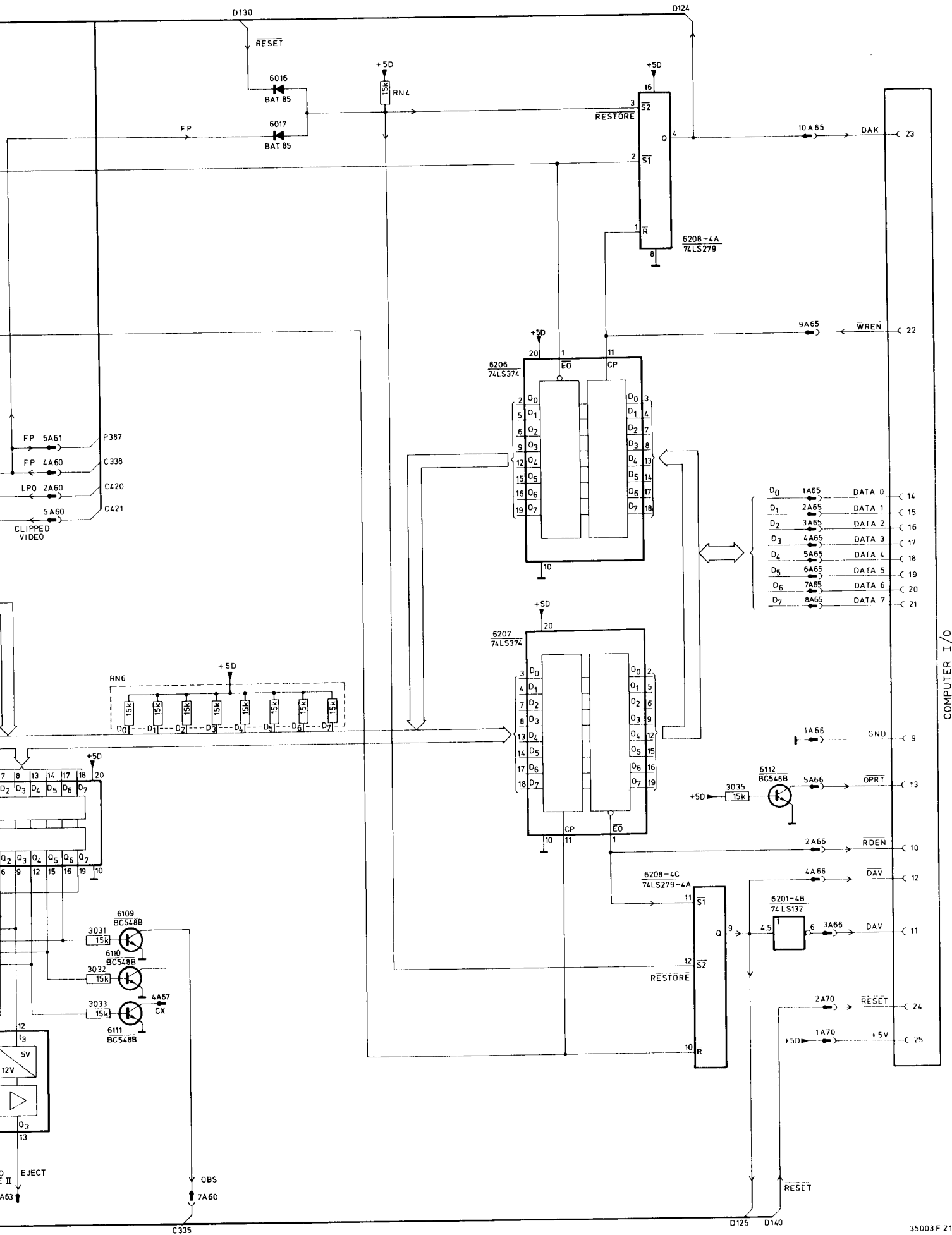

COMPUTER I/O

# DATIC CIRCUIT DIAGRAM D'

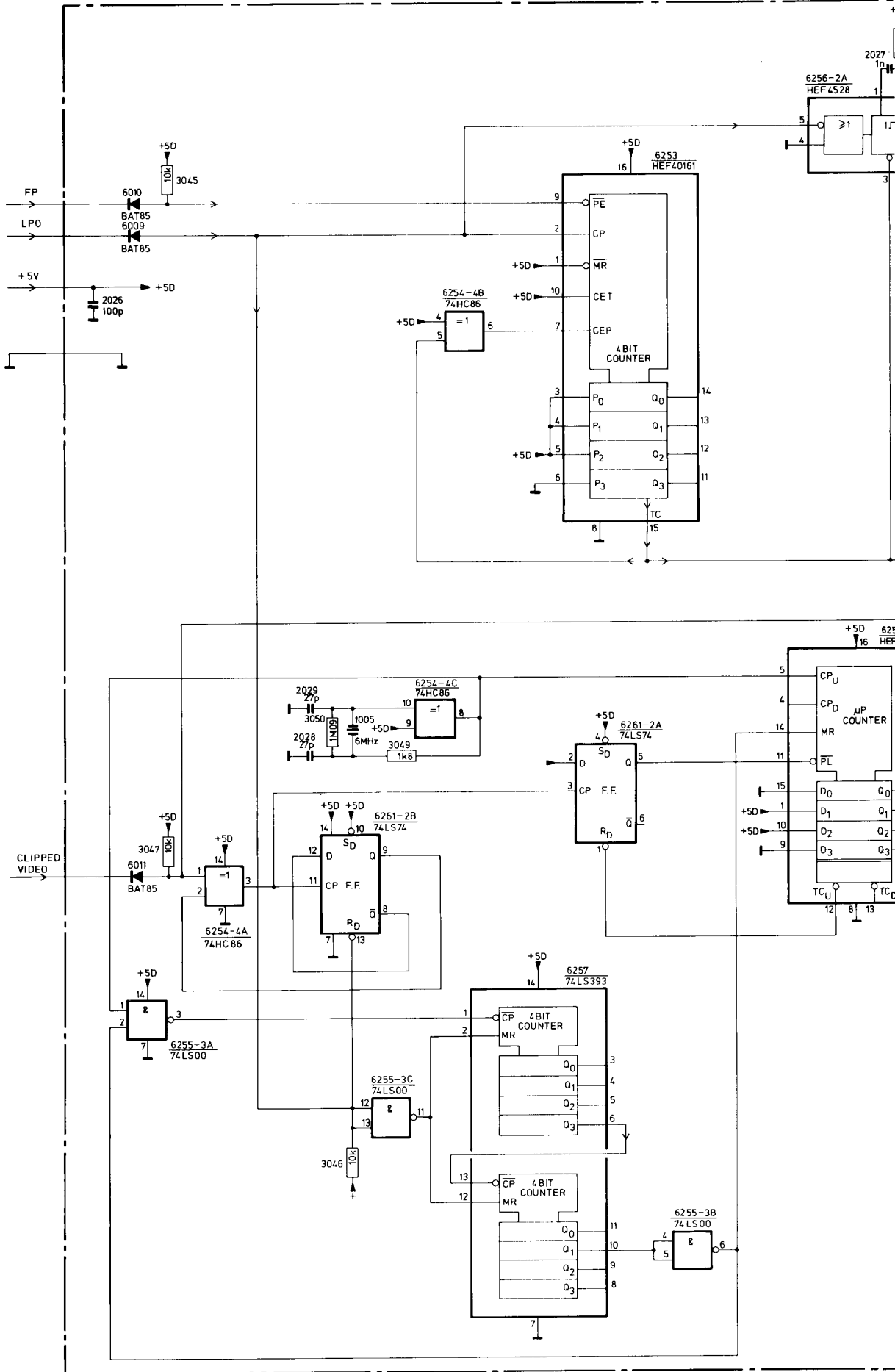

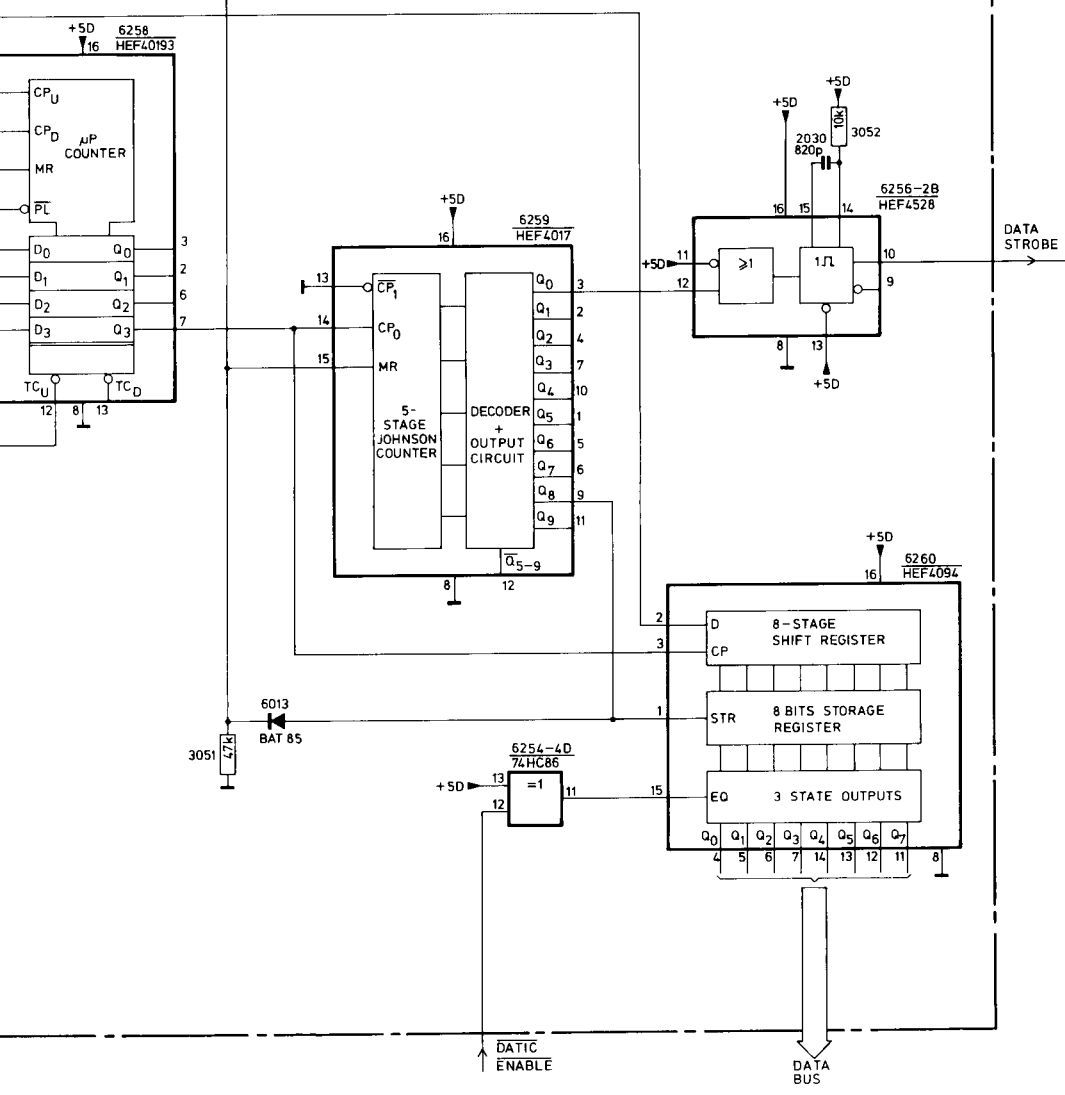
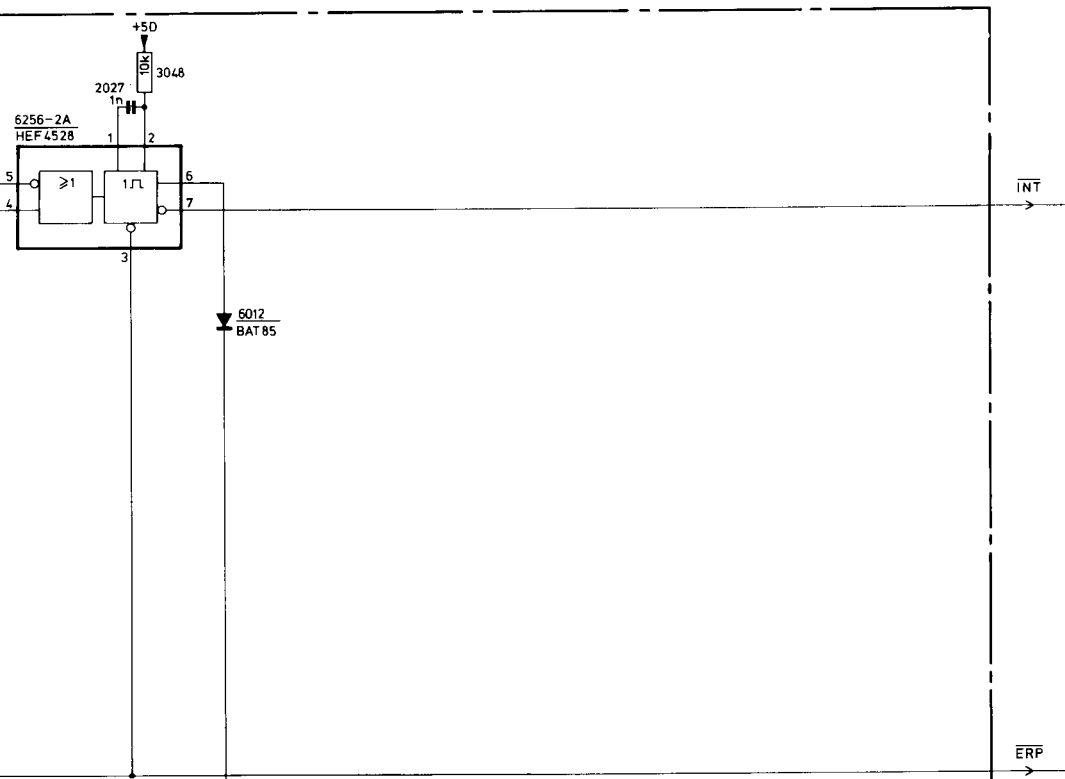

# DECK ELECTRONICS DIAGRAM E

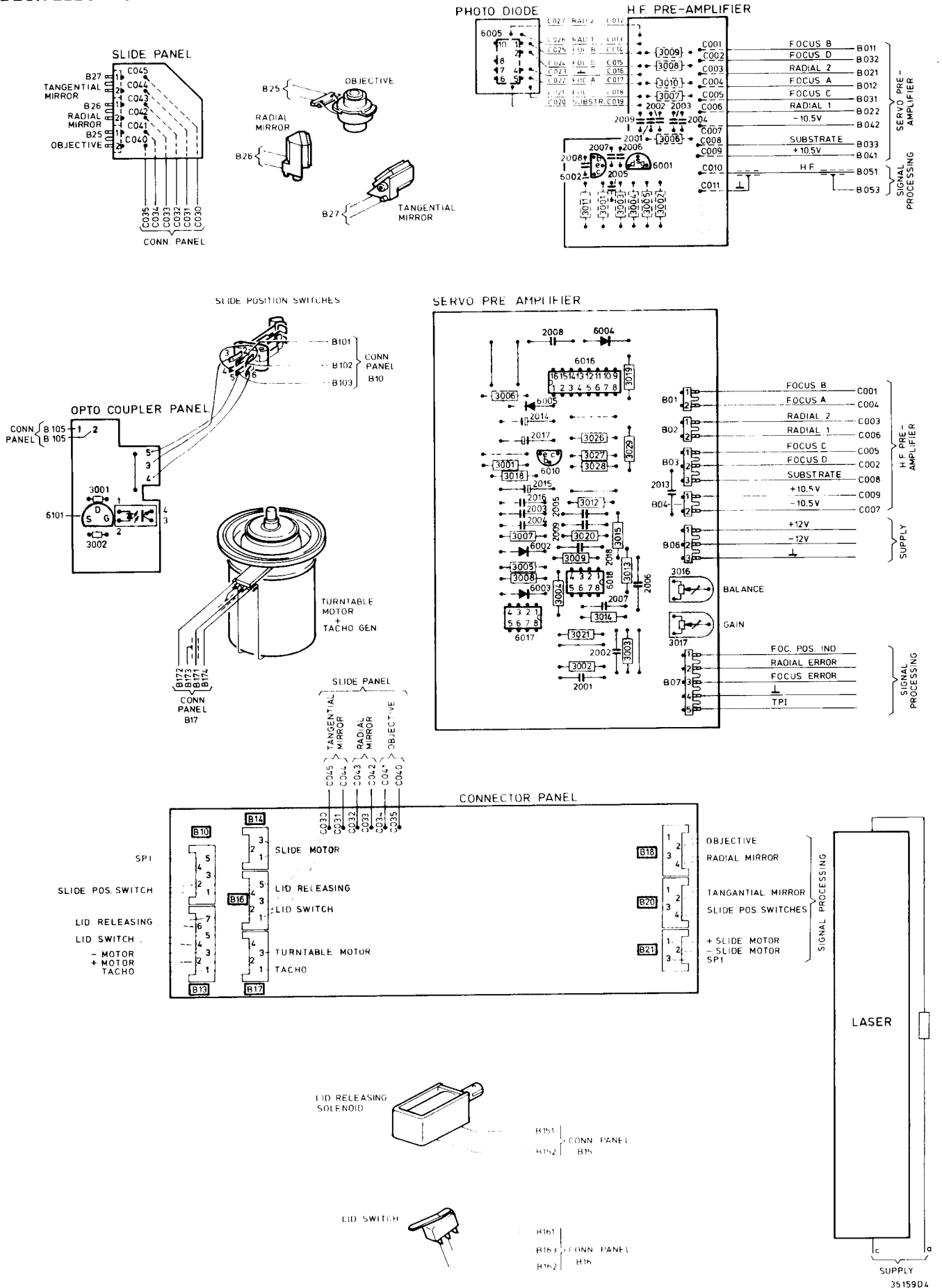

# DECK ELECTRONICS DIAGRAM E

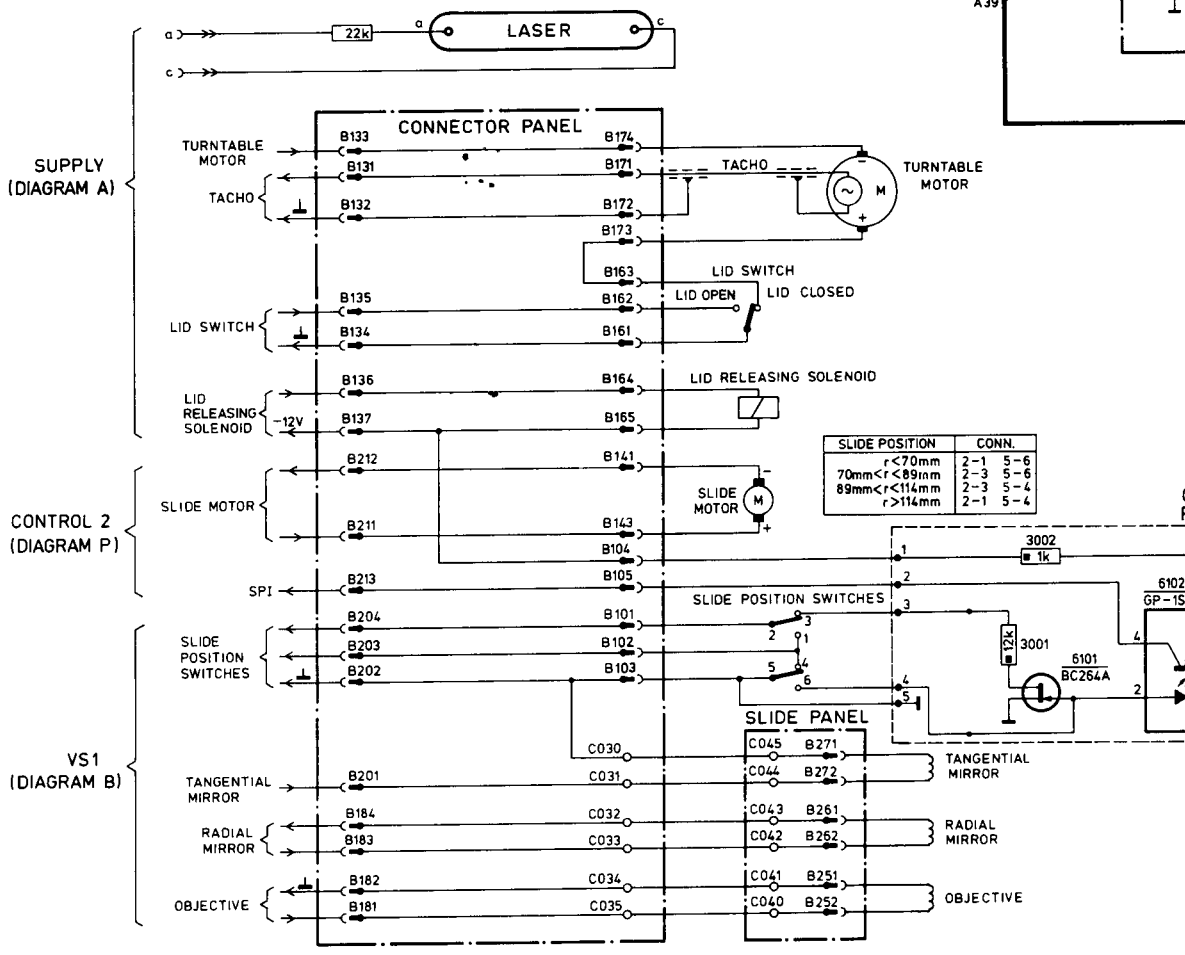
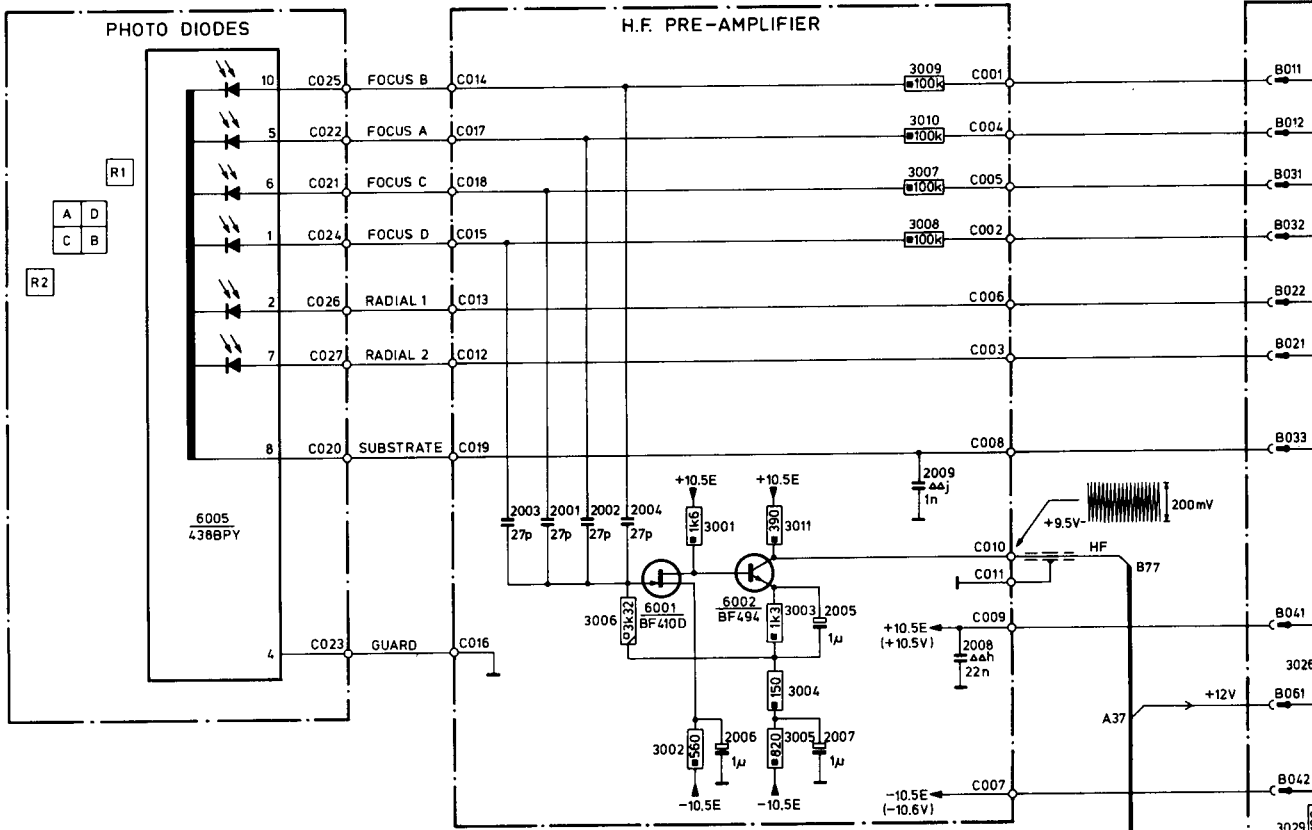

# SERVO PRE-AMPLIFIER

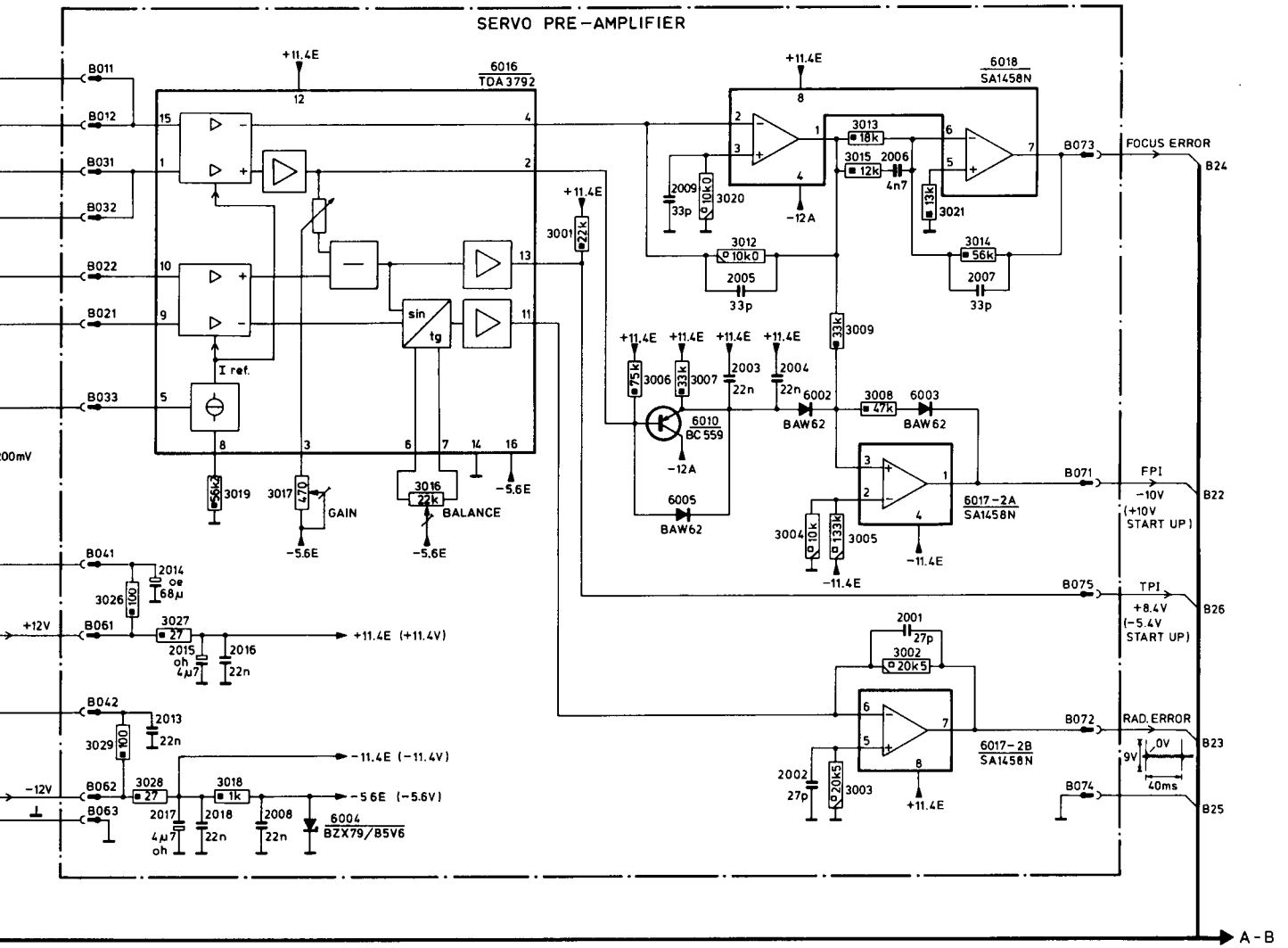

27383E8/C

## OPTO-COUPLER PANEL

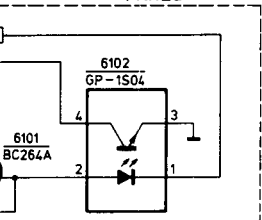

# CONTROL 2 PANEL DIAGRAM D

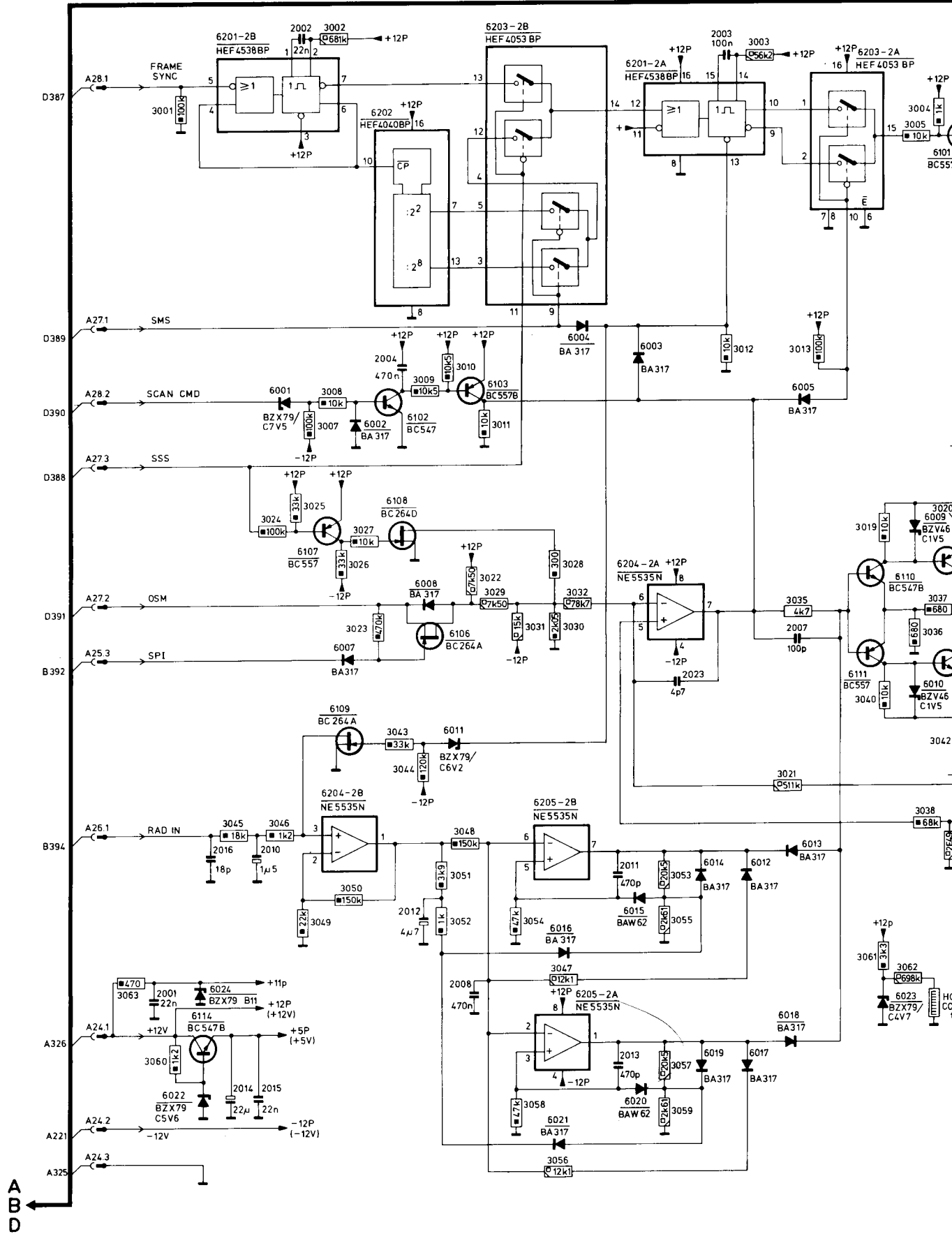



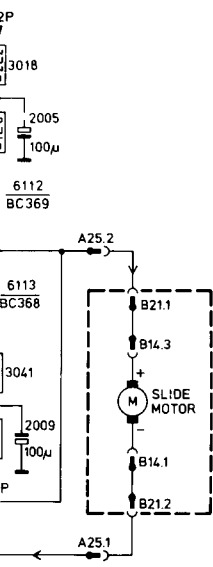
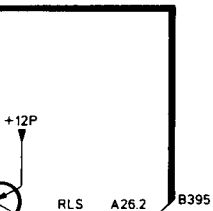

1001	B	1	2014	B	5	3005	E	2	3020	E	5	3035	E	4	3050	D	3	3067	A	2	6007	F	3	6022	B	5	6112	E	4	9002	B	5	9017	C	3	9032	E	1	
1002	A	4	2015	B	5	3006	E	2	3021	E	4	3036	D	5	3051	D	4	3068	A	2	6008	E	3	6023	C	1	6113	E	5	9003	B	5	9018	C	3	9033	E	1	
2001	C	2	2016	B	1	3007	F	2	3022	F	3	3037	F	4	3052	D	4	3070	B	2	6009	F	4	6026	B	4	6114	B	5	9004	B	5	9019	C	3	9034	E	1	
2002	C	1	2017	B	5	3008	E	1	3023	E	3	3038	F	4	3053	D	5	3071	B	1	6010	F	5	6027	B	4	6115	B	1	9005	B	3	9020	C	3	9035	E	2	
2003	C	2	2018	B	5	3009	E	2	3024	F	3	3039	F	3	3054	D	4	3072	B	2	6011	D	2	6101	F	2	6116	A	4	9006	A	2	9021	C	3	9036	E	3	
2004	E	2	2019	A	3	3010	E	2	3025	E	3	3040	E	5	3055	D	5	3073	B	1	6012	D	4	6102	F	1	6201	D	1	9007	A	2	9022	D	5	9037	E	3	
2005	E	4	2020	A	3	3011	E	1	3026	F	3	3041	F	5	3056	C	3	3074	B	4	6013	D	5	6103	F	2	6202	C	1	9008	A	2	9023	D	5	9038	E	4	
2006	E	4	2021	B	3	3012	D	2	3027	F	3	3042	F	5	3057	C	3	3075	B	4	6014	D	4	6104	F	4	6203	D	1	9009	A	2	9024	D	5	9039	E	5	
2007	D	4	2022	B	3	3013	F	2	3028	F	3	3043	D	3	3058	C	3	3076	B	5	6015	C	4	6105	F	4	6204	F	3	9010	A	2	9025	D	4	9040	E	6	
2008	D	5	2025	B	4	3014	F	4	3029	F	3	3044	D	3	3059	C	3	6001	F	1	6016	C	3	6106	F	3	6205	D	4	9011	B	2	9026	D	1	9041	F	3	
2009	F	5	2026	B	4	3015	F	4	3030	F	3	3045	E	3	3060	B	5	6002	E	1	6017	C	2	6107	F	3	6206	C	4	9012	B	2	9027	D	2				
2010	E	3	3001	D	1	3016	F	4	3031	F	3	3046	D	3	3061	C	1	6003	F	1	6018	C	4	6108	F	3	6207	A	2	9013	B	1	9028	D	2				
2011	D	4	3002	C	1	3017	F	4	3032	E	3	3047	C	4	3062	C	2	6004	F	1	6019	C	3	6109	F	3	6208	B	3	9014	A	2	9029	D	2				
2012	D	5	3003	C	2	3018	F	4	3033	F	4	3048	D	4	3063	C	3	6005	F	1	6020	D	3	6111	D	5	6209	B	3	9015	B	3	9030	E	3				
2013	C	3	3004	E	2	3019	F	4	3034	E	4	3049	D	3	3066	C	3	6006	D	1	6021	D	3	6111	D	5	9001	A	5	9016	C	2	9031	E	2				

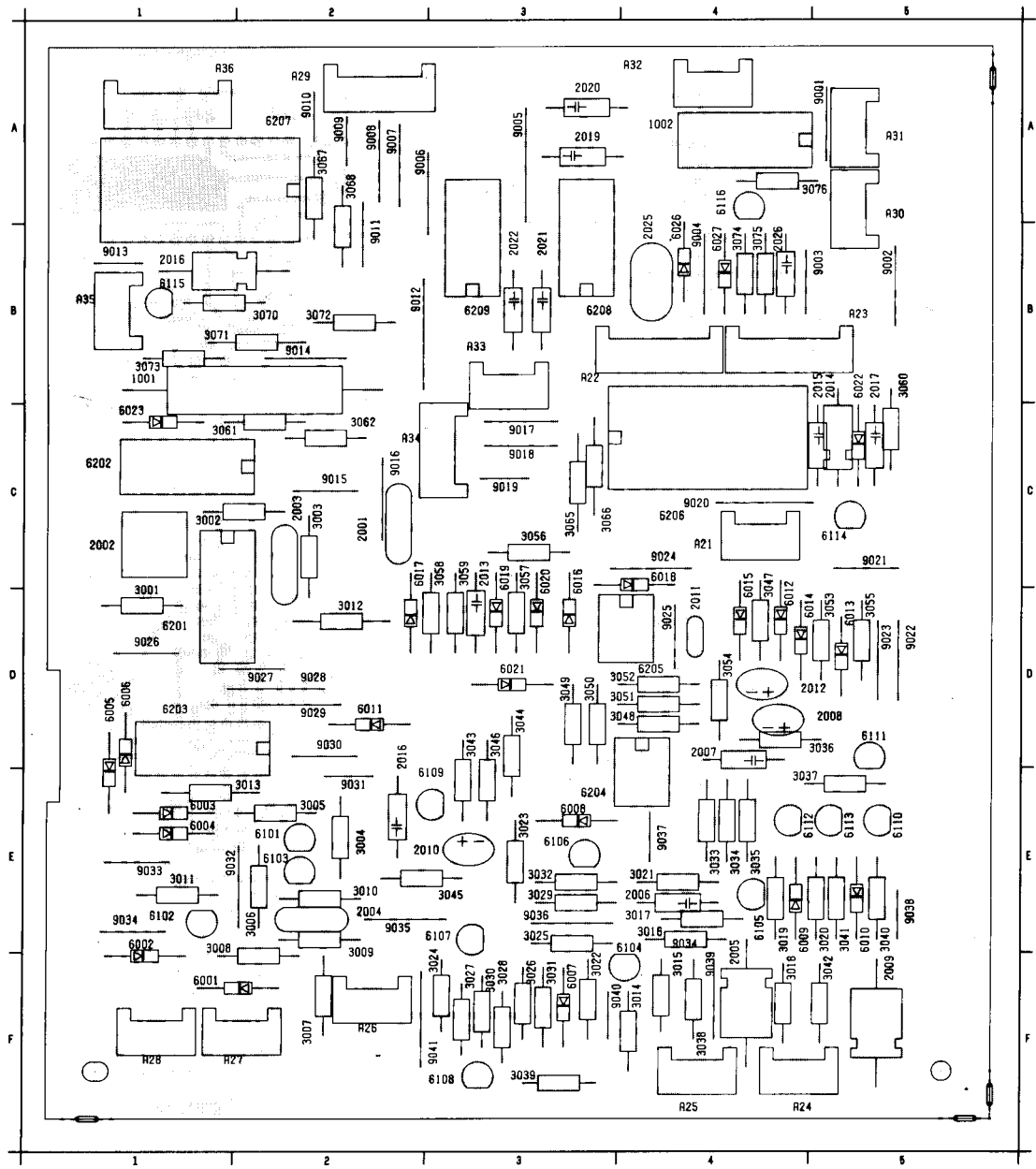

# WIRING DIAGRAM

## TRAFO

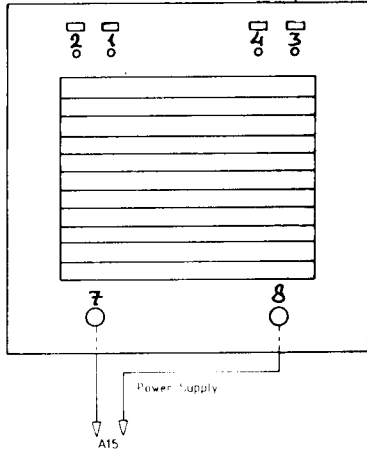

## CONTROL 2

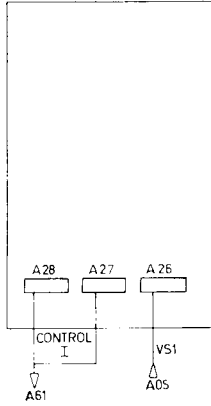

## POWER SUPPLY

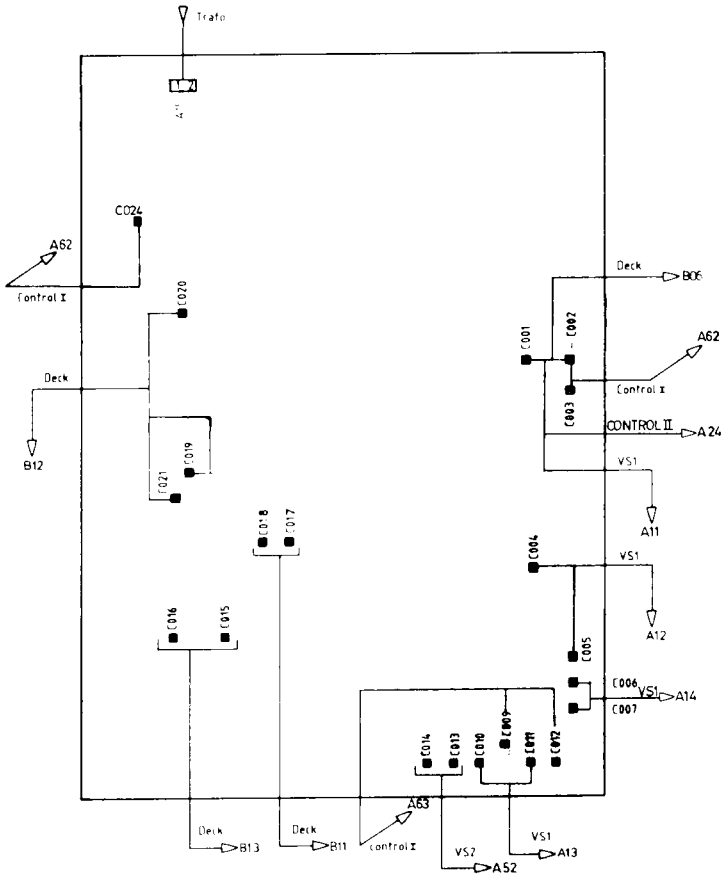

## DECK

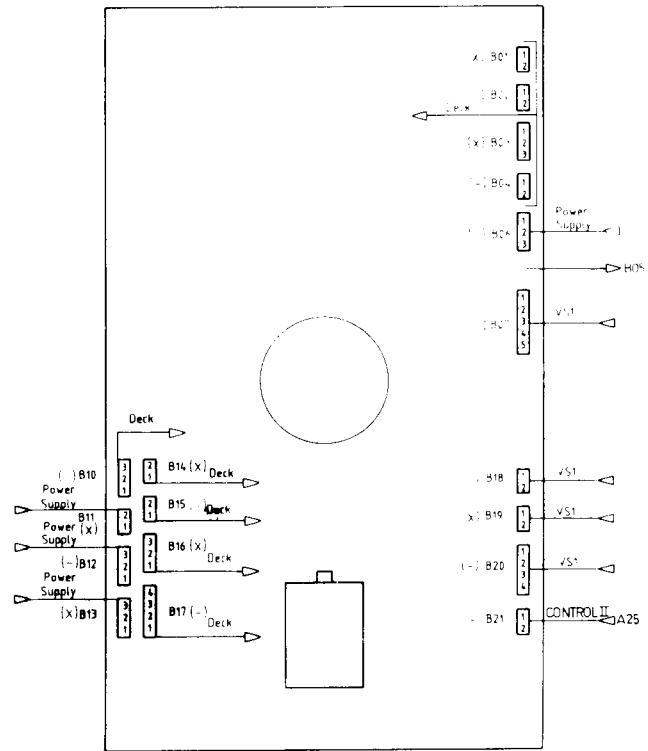

CONTROL 1

CONTROL 2

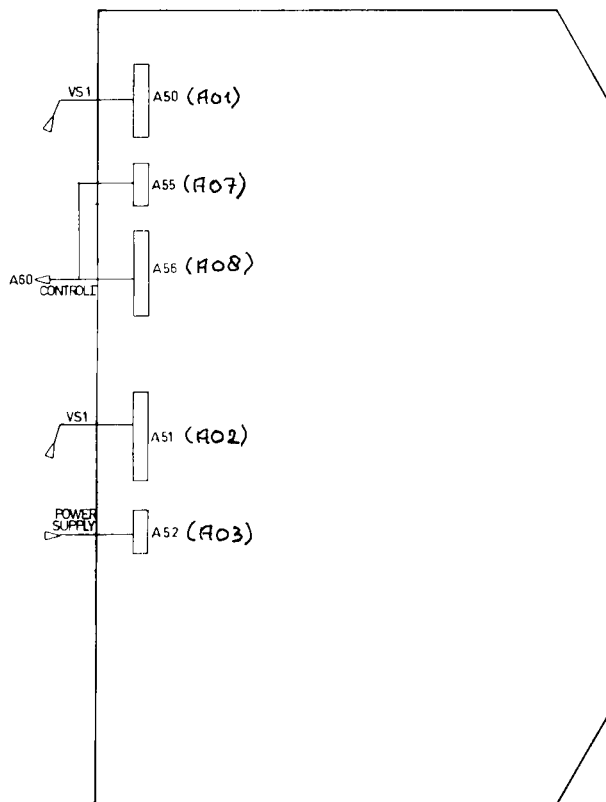
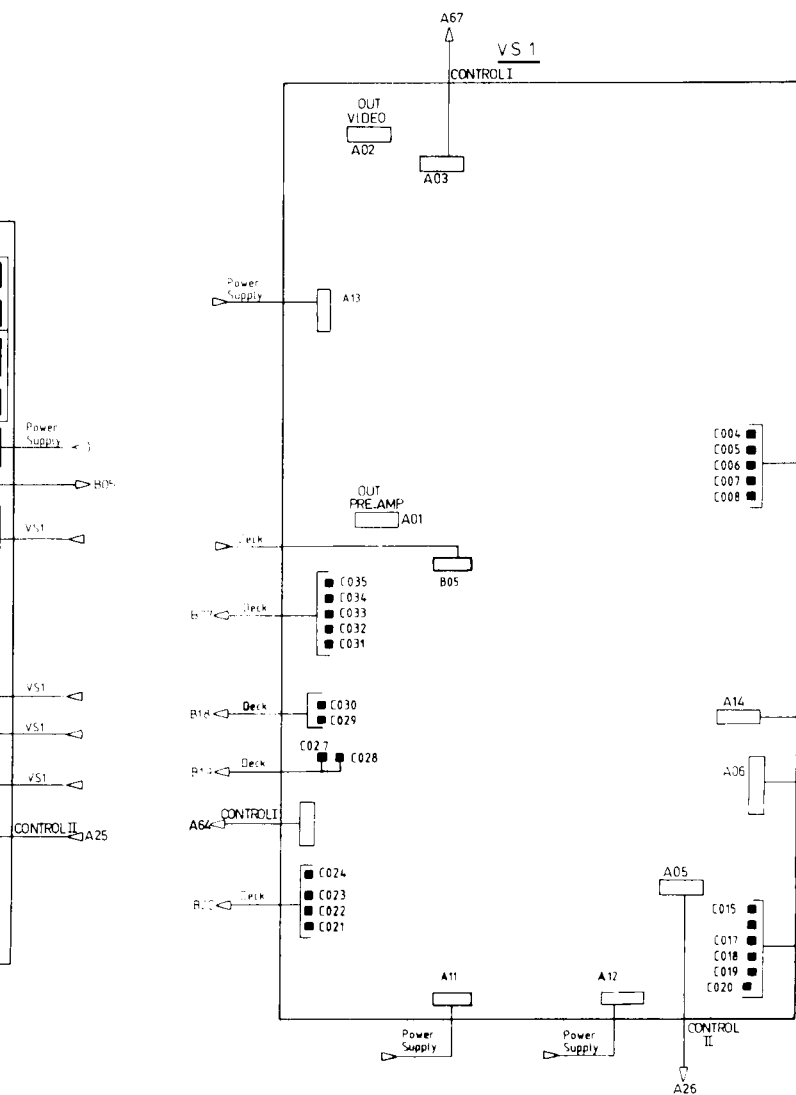
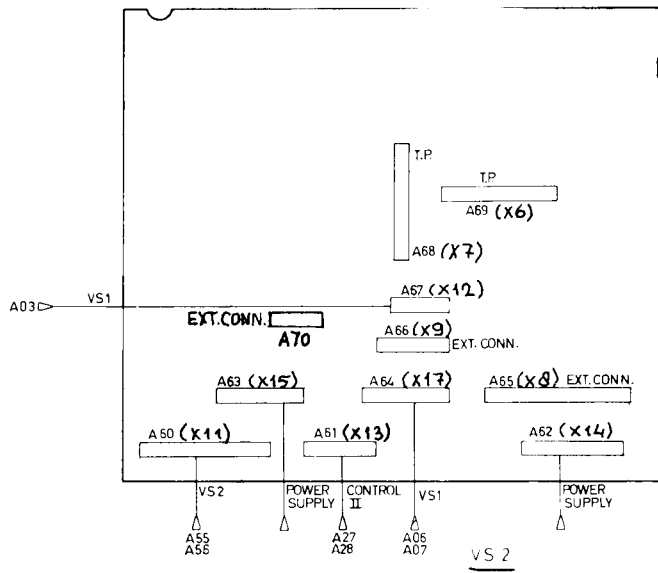
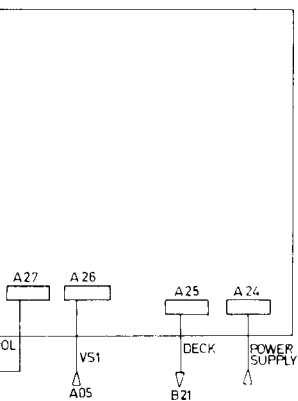

# EXPLODED VIEW PLAYER

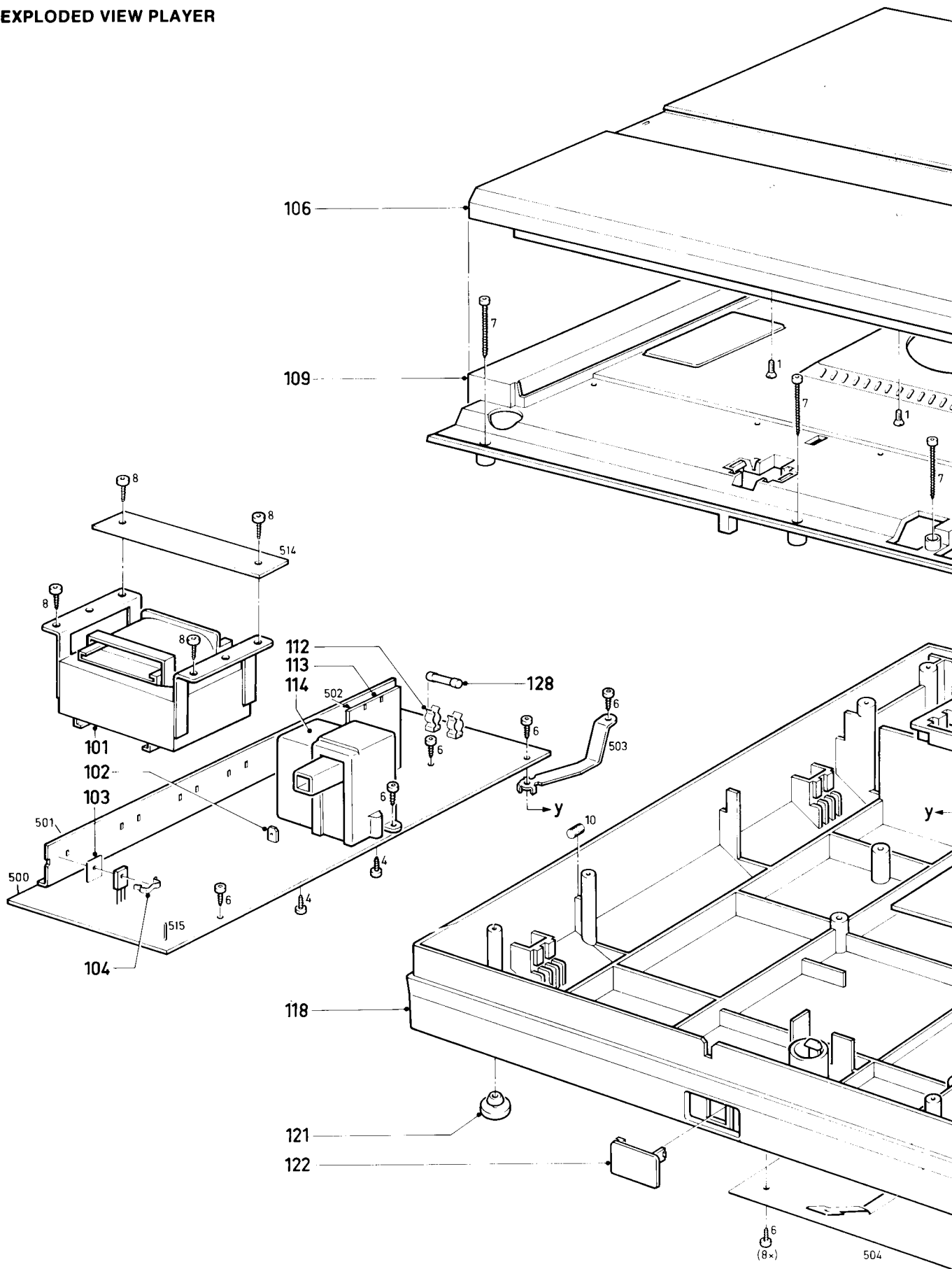

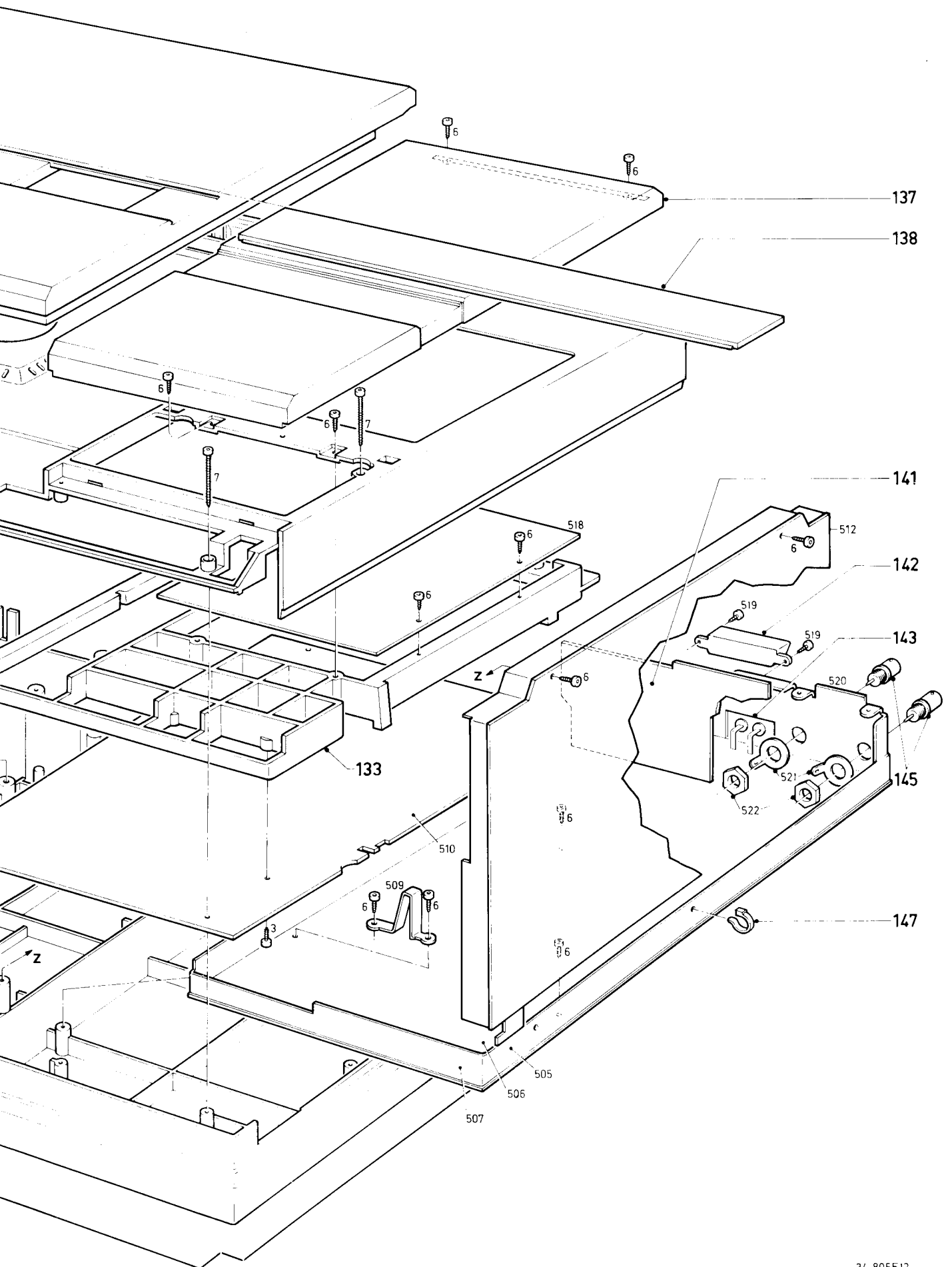

**LIST OF MECHANICAL PARTS PLAYER**

1	Screw M3x6	4822	502	11064
3	Screw 4Nx3/8"	4822	502	30188
4	Screw 4Nx3/8"	4822	502	30209
5	Screw 4Nx3/8"	4822	502	30219
6	Screw 4Nx1/2"	4822	502	30091
7	Screw 4Nx1 1/4"	4822	502	30248
8	Screw 6Nx5/8"	4822	502	30189
	Screw 4Nx20	4822	502	30325
	Screw 4Nx32	4822	502	30316
10	Stopper	4822	462	40155
101	Mainstransformer	4822	146	30479
102	Connector	4822	268	10134
103	Insulating plate	4822	255	40133
104	Spring clip	4822	255	40128
106	Lid cover	4822	444	60398
109	Sub cabinet	4822	444	40111
112	Fuseholder	4822	492	60063
113	Sub supply panel	4822	214	50364
114	Multiplier	4822	214	50231
118	Cabinet	4822	444	50306
121	Foot	4822	462	40414
122	Window	4822	459	20247
128	Fuse	4822	253	30026
133	Frame	4822	464	50269
137	Cover	4822	444	60399
138	Window	4822	450	60378
141	Audio demodulator	4822	214	50362
142	Computer connect.	5322	267	64057
143	Audio connector	4822	267	30469
145	BNC connector	4822	267	10072
147	Ti rap	4822	401	10632

**Service aids**

Testdisc 8" NTSC	4822	397	30097
Testdisc 12" NTSC	4822	397	30098
Set with torx screw-driving tools	4822	395	50145
Opt. alignment set 110V	4822	395	30233
Opt. alignment set 220V	4822	395	30124

**LIST OF ELECTRICAL PARTS PLAYER**

**Panels**

Supply panel	4822	214	50365
Video Servo 1 panel	4822	214	50361
Video Servo 2 panel	4822	214	50359
Control 1 panel	4822	214	50366
Control 2 panel	4822	214	50363
Sub supply panel	4822	214	50364
Audio demodulator	4822	214	50362

**Supply panel**

1001	Fuse 2.5 A	4822	253	30026
1002	Multiplier	4822	214	50231
5002,5005	Transformer	4822	146	30484
5003	Transformer	4822	146	20694
5001,5004	Coil 25 uH	4822	158	10573
5006	Coil 1 mH	4822	157	51589
3011,3066	Potm. 1 kE	4822	100	10037
3112	Potm. 100 kE	4822	100	10052
3098	NTC 4.7 kE	5322	116	30239
	Socket 2f top	5322	267	34085

**Sub supply panel**

5001	Coil 100 uH	4822	156	21251
------	-------------	------	-----	-------

**Video Servo 1 panel**

5004	Delay line	4822	320	40105
5015	Delay line	4822	320	40081
5001	Coil 4 uH	4822	156	21236
5002,5010	Coil 44 uH	4822	156	21243
5003,5005	Coil 2 uH	4822	156	21048
5006,5007	Coil 82 uH	4822	158	10472
5009	Coil 6.4 uH	4822	156	21237
5012	Coil 37 uH	4822	156	21052
5013	Coil 29 uH	4822	156	21241
5014	Coil 28 uH	4822	156	21239
5016	Coil 50 uH	4822	156	21244
5018	Coil 47 uH	4822	156	10525
5020	Coil 39 uH	4822	156	21242
5021	Coil 12 uH	4822	156	21238
5023	Coil 100 uH	4822	156	21049
5030,5034	Coil 4.7 uH	4822	156	20917
5026	LC2004C	4822	218	10155
5027	LC2005C	4822	218	10154
	Potmeters			
3051,3075	1 kE	5322	100	10112
3108	470 E	4822	100	10038
3223	220 kE	4822	100	10088
3383	4.7 kE	4822	100	10036

**Video Servo 2 panel**

5008	Crystal	4822	242	70745
5001	Delay line	4822	320	40104
5002	Coil 10 uH	4822	156	10463
5003,5004	Coil 67 uH	4822	156	21257
5005	Coil 12 uH	4822	156	21238
5006	Coil 210 uH	4822	156	21247
5007	Coil 280 uH	4822	156	21248

**Potmeters**

3009	470 E	4822	100	10038
3021	1 kE	4822	100	10037
3033	100 E	4822	100	10075
3057	2.2 kE	4822	100	10029
3089,3093	22 kE	4822	100	10051
3111	100 kE	4822	100	10052

## Control 1 panel

6018	LED CQV80L	4822	130	31984
5005	Crystal	4822	242	70801
5006	Crystal	4822	242	70392
5001/5004	Coil	4822	158	10101
3055.3057	Resistor 15 kE	4822	111	30813
3058	Resistor 10 kE	4822	111	30814
	IC socket 24p	4822	255	40159
	IC socket 40p	5322	255	44217

## Audio demodulator

5051,5052	Coil 8 mH	4822	156	20928
5053,5055	Coil 86 uH	4822	156	21246
5054,5056	Coil 70 uH	4822	156	21245
3501	Potmeter 1 k	5322	100	10112

## Safety resistors NFR25

6.8	E	4822	111	30504
22	E	4822	111	30517
33	E	4822	111	30522
47	E	4822	111	30526
56	E	4822	111	30528
68	E	4822	111	30531
82	E	4822	111	30533

## IC's

HEF40161BP	5322	209	10344
HEF4017 BP	4822	209	10297
HEF4030 BP	5322	209	14124
HEF40374BP	5322	209	10385
HEF4040 BP	5322	209	14269
HEF4053 BP	5322	209	14121
HEF4066 BP	5322	209	14104
HEF4081 BP	4822	209	10269
HEF4093 BP	5322	209	14927
HEF4094 BP	5322	209	14485
HEF4104 BP	4822	209	10273
HEF4528 BP	4822	209	10277
HEF4538 BP	4822	209	10291

LM393N	4822	209	80797
--------	------	-----	-------

MAB8049HP	4822	209	10405
D 8049PC NEC	4822	209	81976

MC1458N	4822	209	81349
---------	------	-----	-------

NE5535N	4822	209	81132
---------	------	-----	-------

NJM4558D	4822	209	80401
NJM4562D	4822	209	81979
N74HC86	4822	209	81923

N74LS00N	5322	209	84823
N74LS74AN	4822	209	80782
N74LS132N	5322	209	85201
N74LS139N	5322	209	85839
N74LS193N	5322	209	85405
N74LS279N	5322	130	42021
N74LS373N	5322	209	86062
N74LS374N	5322	209	85869
N74LS393N	4822	209	80447

TCA420A	4822	209	80278
---------	------	-----	-------

TDA2730	4822	209	80744
---------	------	-----	-------

UAA1030	4822	209	80794
---------	------	-----	-------

2732	4822	209	81924
------	------	-----	-------

MM2716Q	4822	209	81975
---------	------	-----	-------

## Transistors

BC264A	5322	130	44476
BC264B	4822	130	41066
BC264C	5322	130	44476
BC264D	5322	130	44656
BC327	4822	130	40854
BC327A	4822	130	42155
BC327/40	4822	130	41327
BC337	4822	130	40855
BC337A	4822	130	42032
BC368	5322	130	44647
BC369	5322	130	44593
BC546	4822	130	41001
BC546B	4822	130	44461
BC547	4822	130	44257
BC547C	4822	130	44503
BC548	4822	130	40938
BC548B	4822	130	40937
BC548C	4822	130	44196
BC549	4822	130	40964
BC549B	4822	130	40936
BC549C	4822	130	44246
BC556A	5322	130	44462
BC556B	4822	130	41691
BC557	4822	130	44256
BC557B	4822	130	44568
BC558	4822	150	40941
BC558A	4822	130	40962
BC558B	4822	130	44197
BC559	4822	130	40963
BD236	4822	130	40917
BD437	4822	130	40982
BD438	4822	130	40995
BD675	5322	130	44786
BF240	4822	130	40902
BF256B	5322	130	44744
BF410B	4822	130	41908
BF450	4822	130	44237
BF494	4822	130	44195
BSV78	5322	130	44093
PH2369	4822	130	41594
IRFD120	4822	130	42154

## Diodes

BA317	4822	130	30847
BAT85	4822	130	31983
BAW62	4822	130	30613
BB112	4822	130	32227
BB809	5322	130	31684
BY225/100	4822	130	50312
BYV27/100	4822	130	31982
BZV46/C1V5	5322	130	34865
BZV46/C2V0	4822	130	31248
BZX75/C1V4	4822	130	34047
BZX79/B3V9	4822	130	31981
BZX79/B8V2	4822	130	34382
BZX79/B9V1	4822	130	30862
BZX79/B11	4822	130	34488
BZX79/C3V6	5322	130	34834
BZX79/C4V7	4822	130	34174
BZX79/C5V6	4822	130	34173
BZX79/C6V2	4822	130	34167
BZX79/C7V5	4822	130	30861
BZX79/C8V2	4822	130	34382
BZX79/C15	4822	130	34281
BZX79/C18	4822	130	31024
BZX79/C56	4822	130	34258

## Connectors

3P	Top	4822	267	40352
4P	"	4822	267	40353
5P	"	4822	267	40354
6P	"	4822	267	40355
7P	"	4822	267	50285
8P	"	4822	267	50406
9P	"	4822	267	50419
10P	"	4822	267	50332

**EXPLODED VIEW DECK**

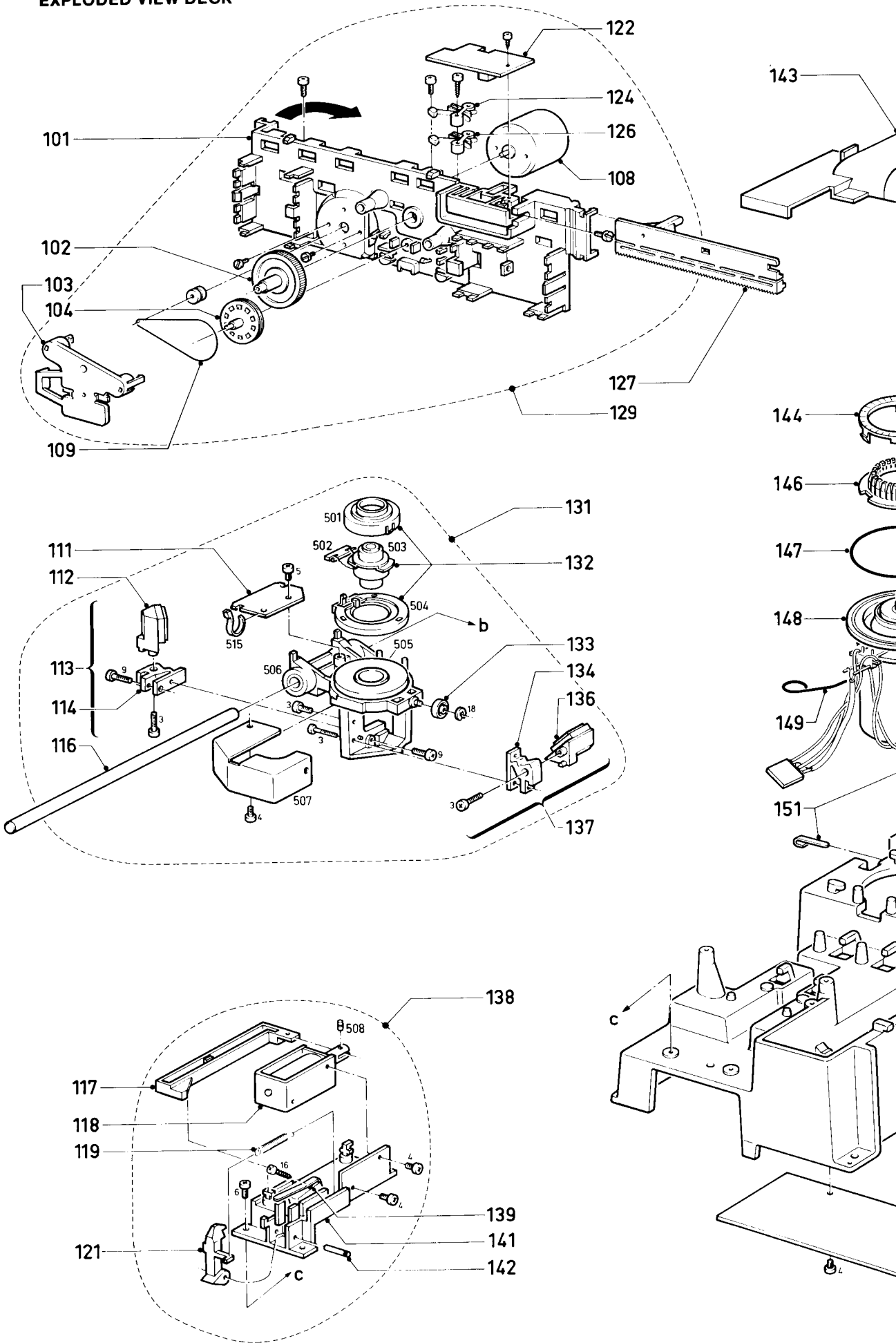



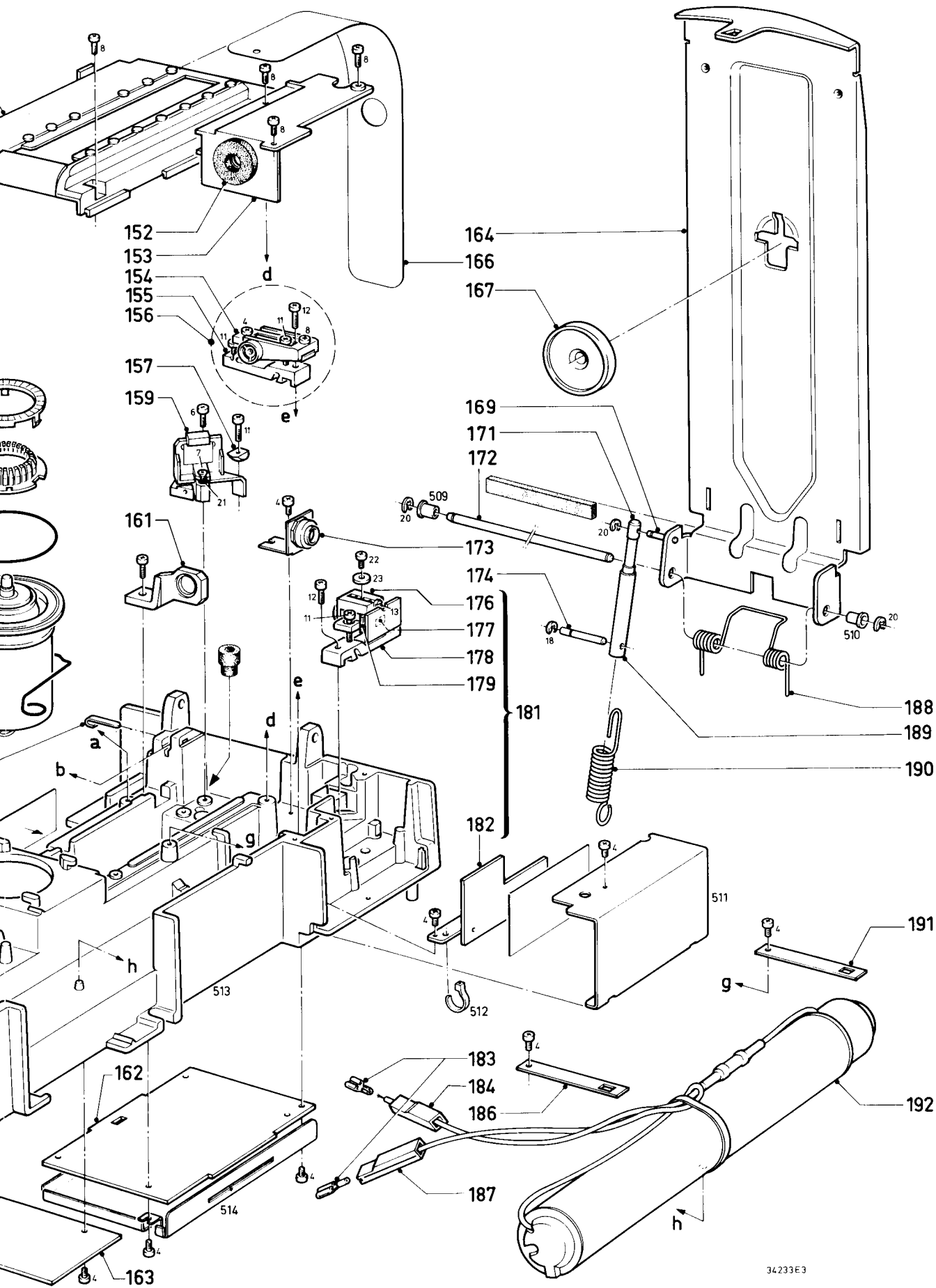

# LIST OF MECHANICAL PARTS DECK

## Fixing material

1a	4822	502	11674	Screw M2x5	134	4822	402	60815	Bracket
1	4822	502	11469	Screw M2.5x5	136,				
2	4822	502	11549	Screw M2.5x10	137	4822	380	20119	* Tangential mirror assy
3	4822	502	11552	Screw M2.5x16	138	4822	218	10151	Lid blocking assy
3a	4822	502	11675	Screw M2.5x16	139	4822	271	30322	* Lid switch
4	4822	502	11472	Screw M3x5	141	4822	464	50183	Bracket
5	4822	502	11526	Screw M3x5	142	4822	535	91259	Spindle
6	4822	502	11473	Screw M3x8	143	4822	444	60396	Dust cover
7	4822	502	11574	Screw M3x8	144	4822	460	20336	Ornamental ring
8	4822	502	11474	Screw M3x10	146	4822	532	60774	Centring ring
9	4822	502	11573	Screw M3x10	147	4822	530	50592	"O"-ring
11	4822	502	11553	Screw M3x15	148	4822	361	30152	* Turntable motor
12	4822	502	11475	Screw M3x16	149	4822	492	62494	Spring
13	4822	502	11554	Screw M3	151	4822	492	62489	Leafspring
13a	4822	502	30307	Screw M4x6	152	4822	532	51176	Ring
14	4822	502	30048	Screw 4Nx16	153	4822	444	30318	Cover
15	4822	502	30308	Screw 4Nx16	154	4822	492	62488	Leafspring
16	5322	502	84013	Screw 2Nx13	155	4822	256	90414	Manipulator holder
17	4822	505	10471	Nut M2.5	156	4822	691	30107	Spot lens/grating man. assy
18	4822	530	70043	Retaining ring 2.3	157	4822	535	20046	Wedge
19	4822	532	10847	Ring 2.7x6.5	159	4822	380	10019	Folding mirror
20	4822	530	70124	Retaining ring 4	160	4822	462	40558	Stop
21	5322	325	64029	Grommet	161	4822	381	10684	Collimating lens
22	4822	502	11064	Screw M3x6	162	4822	214	50261	* Servo pre-amplifier
23	4822	532	10582	Ring 3.2x9	163	4822	263	70181	* Connector panel
24	4822	532	50477	Ring	164	4822	402	60859	Lid bracket
					166	4822	460	10518	Dust strip
					167	4822	532	60775	Clamping piece
					169	4822	535	70644	Pin
					171	4822	360	40107	Plunger
					172	4822	535	91582	Spindle
					173	4822	381	20067	/4 plate assy
					174	4822	535	91263	Spindle
					176	4822	492	62493	Flat spring
					177	4822	130	31572	* Photo diode
					178	4822	402	60814	Diode manipulator
					179	4822	381	40045	Cylinder lens
					181	4822	214	50273	* Photo diode with preamp.assy
					182	4822	214	50373	* H.F. Pre-amplifier
					183	4822	268	20079	Laser connector
					184	4822	268	40098	Anode connector housing
					186	4822	492	62491	Leafspring
					187	4822	268	40099	Cathode connector
					188	4822	492	41014	Tension spring
					189	4822	360	40108	Bush
					190	4822	492	32314	Spring
					191	4822	492	62491	Leafspring
					192	4822	131	41002	* Laser
						4822	390	20107	Grease for damper item 189

## Chassis

-----

101	4822	444	50305	Bracket	172	4822	535	91582	Spindle
102	4822	522	31743	Pulley	173	4822	381	20067	/4 plate assy
103	4822	462	40651	Bracket	174	4822	535	91263	Spindle
104	4822	528	80956	Pulley	176	4822	492	62493	Flat spring
108	4822	361	20442	* Slide drive motor	177	4822	130	31572	* Photo diode
109	4822	358	30386	Belt	178	4822	402	60814	Diode manipulator
111	4822	214	50263	* Slide panel	179	4822	381	40045	Cylinder lens
112,					181	4822	214	50273	* Photo diode with preamp.assy
113	4822	380	20118	* Radial mirror assy	182	4822	214	50373	* H.F. Pre-amplifier
114	4822	402	60815	Bracket	183	4822	268	20079	Laser connector
116	4822	535	91261	Spindle	184	4822	268	40098	Anode connector housing
117	4822	402	60817	Bracket	186	4822	492	62491	Leafspring
119	4822	492	32073	Tension spring	187	4822	268	40099	Cathode connector
121	4822	526	50058	Pawl	188	4822	492	41014	Tension spring
122	4822	402	60885	* Slide stop panel	189	4822	360	40108	Bush
124,					190	4822	492	32314	Spring
126	4822	271	30255	* Slide position switch	191	4822	492	62491	Leafspring
127	4822	522	31742	Rack	192	4822	131	41002	* Laser
129	4822	691	30127	Slide drive assy		4822	390	20107	Grease for damper item 189
131	4822	691	30108	Slide assy					
132	4822	256	80046	* Objective assy					
133	4822	528	90376	Wheel					

\* See also list of electrical parts

# LIST OF ELECTRICAL PARTS DECK

Printed panels (only available during production)

H.F. pre-amplifier	4822 214 50373
Servo pre-amplifier	4822 214 50261
Connector panel	4822 263 70181
Slide panel	4822 214 50263
Slide stop panel	4822 402 60885
Laser	4822 131 41002



Turntable motor	4822 361 30152
Slide motor	4822 361 20442



Lid switch	4822 271 30322
Slide position switch	4822 271 30255



Objective assy	4822 256 80046
Radial mirror assy	4822 380 20118
Tangential mirror assy	4822 380 20119



Photo diode	4822 130 31572
Photo interruptor	4822 130 32114



SA1458N	4822 209 80793
TDA3792	4822 209 81029

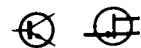

BC264A	5322 130 44476
BC559	4822 130 40963
BF410D	4822 130 41697
BF494	4822 130 44195

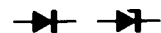

BAW62	4822 130 30613
BZX79/B5V6	4822 130 34173



470 E	4822 100 10038
22 kE	4822 100 10051

## MR25

3.32 kE	5322 116 54005
10 kE	4822 116 51253
20.5 kE	5322 116 55419
56.2 kE	4822 116 51264
133 kE	5322 116 54708
100 kE	4822 116 51268

## Servo pre-amplifier



2014	68 uF-16V	4822 124 20689
2015,2017	4.7 uF-63V	4822 124 20726



2001,2002	27 pF-50V	4822 122 10215
2003,2004,		
2008,2018	22 nF	4822 122 10188
2005,2007,		
2009	33 pF-50V	4822 122 10179
2006	4.7 nF	4822 121 50539

## H.F. Pre-amplifier

2001..2004	27 pF-100V	4822 122 30045
2005,2007	1 uF- 25V	4822 124 21457



1 nF	100V	4822 122 30027
22 nF	63V	4822 122 30103

## Print connectors



2f-top	4822 267 30339
2f-top	5322 267 34085
3f-top	4822 265 30144
3f-top	4822 268 10133
4f-top	4822 267 40258
5f-top	4822 267 40342
2f-bottom	4822 267 30361
2f-bottom	4822 267 30405
3p-top	4822 267 40352
4p-top	4822 267 40353
5p-top	4822 267 40354
7p-top	4822 267 50285